

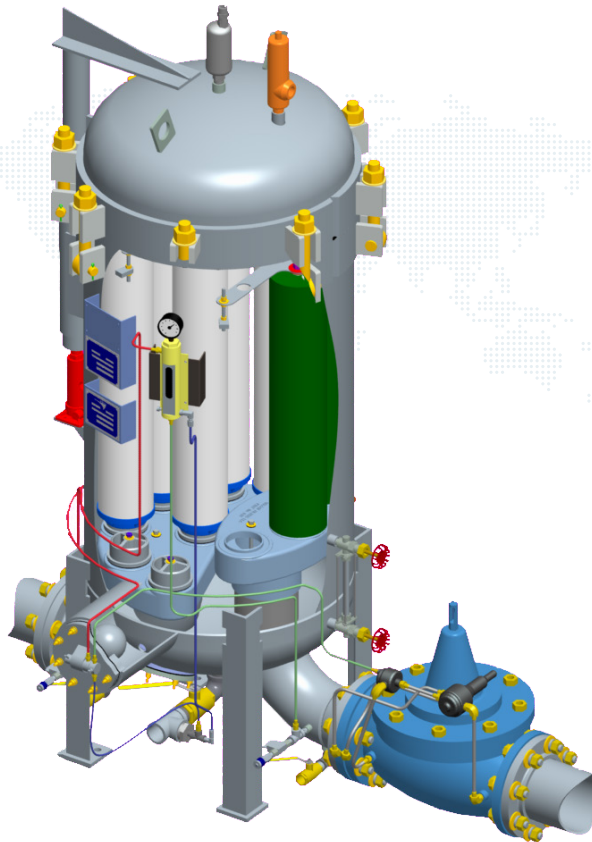

VEL2162R2 0819

Aerospace Filtration Division

Effective: August 2019



---

# Standard Filter/Separator Installation and Operation Manual

---

Parker Hannifin Corporation  
**Aerospace Filtration Division**  
1210 Garden of the Gods Road  
Colorado Springs, CO 80907  
+1 719 531 5855 Phone  
+1 719 531 5690 Fax  
[www.velcon.com](http://www.velcon.com) | [www.parker.com](http://www.parker.com)  
[vfsales@parker.com](mailto:vfsales@parker.com)

ENGINEERING YOUR SUCCESS.

# **WARNING**

**DO NOT PRESSURE TEST  
THIS VESSEL WITH AIR!**

**PRESSURE TESTING  
WITH AIR IS A  
HAZARDOUS PROCEDURE!**

**THIS VESSEL IS TO BE PRESSURIZED  
ONLY WITH THE LIQUID FOR WHICH  
IT IS INTENDED TO BE USED AND  
ONLY TO THE MAXIMUM DESIGN  
PRESSURE SHOWN ON THE VESSEL  
NAME PLATE.**

**TABLE OF CONTENTS**

General Description.....	5
First Stage – Coalescer Cartridges .....	5
Second Stage – Separator Cartridges .....	5
Installation of Vessel.....	5-6
Start-Up Procedure .....	6
Cartridge Installation .....	6
First Stage Coalescer Cartridges.....	6-7
Separator Cartridges .....	7-8
Operating Information .....	8-9
Cartridge Change or Inspection Procedure .....	9-10
Sump Checks.....	10

**Installation Instructions**

Threaded Base Cartridges .....	12
Open-Ended Coalescer Cartridges .....	13
Separator Cartridges.....	14
Torque Requirements for Vessels with O-ring Closure.....	15
Tie Rods .....	16-17

**Appendix/Accessories**

A: Function of Filter/Separator Accessories.....	20
B: The Importance of Spiders .....	21-22
C: Assembly Torque Recommendations .....	23-24
D: Coalescing for Aviation Fuel Use.....	25-28
E: DI & DSO Particulate and Water Removal from Diesel Fuel .....	29-30
F: Cartridge Changeout Curve .....	31
G: Separator Cartridges .....	32-33
H: Maintenance of PTFE Coated Screen Separator Cartridges.....	34-35
I: Coalescer/Separator Cartridges for Aviation Fuel - EI 1581 5 <sup>th</sup> Edition.....	36-37
J: Similarity Certification Form.....	38

DISCLAIMER: This generic vessel manual is provided for your information with the understanding that each vessel sent out from Velcon is customized for the particular vessel and contains accessory information not included in this document. This document makes references to other pieces of literature, such as schematics and drawings that are added to the manual as needed depending on the vessel parameters.



**GENERAL DESCRIPTION**

The Parker Velcon Filter/Separator system you received consist of the vessel, cartridges, and accessory equipment to meet your specific requirements. Descriptive literature covering the accessories is included near the back of this manual.

Parker Velcon systems are manufactured to meet a variety of different end uses and specifications. The finest workmanship has gone into the building of this Parker Velcon filter/separator. If the unit is operating improperly, we urge you to read the manual carefully and follow the instructions given; it maybe the cartridges were improperly installed.

To optimize filters/separators for efficiency and performance, a prefilter vessel is recommended for use upstream of the fuel filter water separator. The prefilter is over sized to increase efficiency and filter life of the filter/separator.

A Parker Velcon Filter/Separator system is specifically designed to remove solid contaminants and/or water from the product. To accomplish this, the filter/separator is equipped with two types of cartridges through which the product passes in sequence.

**FIRST STAGE - COALESCER CARTRIDGES**

These cartridges have two functions—filter solid contaminants out of the product and coalesce water into droplets. Any water present in the influent product is usually emulsified into tiny particles by the action of the pumps handling the product. The first stage cartridges coalesce these particles into droplets of sufficient size for gravity to settle out of the product rapidly into the sump of the vessel.

**SECOND STAGE - SEPARATOR CARTRIDGES**

The function of the second stage cartridges is to repel coalesced water droplets that have not yet settled from going downstream with the product.

The water should be drained manually on a daily basis. Automatic drain valves have a fail rate and are not recommended for Velcon vessels. The automatic drains values can often malfunction and result in draining the fuel tanks completely onto the ground. Resulting in costly environmental cleanup, subsequent environmental problems, and fuel replacement costs.

Proper provision for drainage of accumulated water is of key importance in the operation of any filter/separator. If the water level gets too high, either it will be carried downstream or cause shut-down of a system equipped with slug controls.

The filter/separator shown in the appendix, Bulletin 1215, is a typical Vertical Model. Your filter/separator may be a Horizontal Model with the separator cartridges mounted above or opposite the coalescer cartridges. The operating principles are the same, however.

**INSTALLATION OF VESSEL**

1. Identify the filter/separator inlet and outlet by the markings provided on the vessel piping. The filter/separator must be installed in the correct direction of flow to perform properly and to avoid damage to the system.
2. INLET and OUTLET PIPING should be carefully aligned to avoid stressing the filter/separator connections during installation. Installation of shut-off valves on either side of the filter/separator is recommended so that it can be independently drained for cartridge change out or inspection.

 <b>CAUTION</b>	<b>STEPS 3 AND 4 SHOULD BE PERFORMED BEFORE REMOVING HINGE OR PIVOT MOUNTED COVER TO ENSURE STABILITY OF THE FILTER/SEPARATOR.</b>
---	--

3. Bolt the filter/separator to a stable base.
4. Carefully install correct gaskets on the inlet and outlet connections and connect to the inlet and outlet piping.
5. Connect any accessories that are not already installed. See Accessory Parts List and literature as required.

<b>NOTE</b>	If a system pressure test or system flush is required, it should be done prior to installing operating cartridges. Install flush cartridges, if required, per instructions on pages 12 and 13. Check the cover gasket for proper alignment, replace the cover and secure tightly. Refer to Torque Requirements for Vessel Closures Installation Instruction (see page 15) for appropriate torque values and tightening sequence. Pressure test and/or flush as required.
-------------	--

 <b>CAUTION</b>	<b>OVERTIGHTENING OF CLOSURE BOLTS OR USE OF PNEUMATIC TOOLS IS NOT RECOMMENDED.</b>
---	--

6. Cartridges are normally packed separately. Open the vessel cover and install cartridges as explained on page 12 and as per enclosed element stack drawings.

7. Check the cover gasket for proper alignment, replace the cover and secure tightly. Refer to Torque Requirements for Vessel Closures Installation Instruction (see page 15) for appropriate torque values and tightening sequence.
3. If the unit is equipped with a manual vent valve, leave the valve cracked open until the fluid flows from the opening; then close quickly.
4. If equipped with an automatic air eliminator, the unit is filled when the air eliminator stops flowing air. When the Velcon filter/separator is filled with fluid, fully open the inlet valve, and slowly open the outlet valve.

<b>NOTE</b>	FILTER/SEPARATOR VESSELS MUST BE EQUIPPED WITH A PRESSURE RELIEF VALVE TO PROTECT THE VESSEL FROM DAMAGE CAUSED BY THE BUILD UP OF PRESSURE, WHICH DEVELOPS FROM THE THERMAL EXPANSION OF THE FUEL WHEN TEMPERATURE LEVELS INCREASE.
-------------	--

<b>NOTE</b>	Prior to operation, the vessel should be equipped with the means to vent air and drain off water. If the vessel does not come equipped with a vent valve or a drain valve, be sure to install a vent valve at the top of the vessel and a manual drain valve at the bottom of the vessel (See Appendix A). Additionally, it is recommended that a drain valve be installed at the bottom of the dirty fuel compartment.
-------------	---

5. When the unit is in operation, take a differential pressure reading and record the reading. The differential pressure ( $\Delta P$ ) should be between 1 and 10 psi depending on the purchase specification. If there is no  $\Delta P$ , the system should be shutdown and the filter/separator inspected for broken seals or possibly cartridges left out (see Differential Pressure Readings starting on page 8).

### CARTRIDGE INSTALLATION

Cartridges, aluminum spiders, and mounting hardware are not normally shipped installed. If they are shipped installed, ensure cartridges and spiders are secure and were not loosened in shipment. Follow the instructions below for subsequent cartridge changes and inspections. If they are not installed, locate the cartridges, spiders and mounting hardware.

### START UP PROCEDURE

If the Parker Velcon filter/separator has the accessories listed below, they should be placed in the following positions:

1. Close all manual drain valves.
2. If the vessel has an automatic air eliminator with an isolation valve below it, open the isolation valve. If not, open the manual vent valve.
3. The valves at the inlet and outlet piping to and from the vessel should be closed.

For information on operation of accessories, turn to the Accessory Instructions in the back of the manual.

After the valves have been positioned as outlined, the unit is ready to be filled.

The following operating instructions can be used for initial start-up and for subsequent start-ups after installation of replacement cartridges or servicing of the unit.

1. Start the system pump.
2. Slightly open the inlet valve, allowing the filter/separator to slowly fill with fluid. Increasing the velocity through the pipe and the coalescer elements too quickly causes static electricity to build up and cause an internal fire to ignite within the vessel. Filling the vessel at a slower flow rate eliminates the build of static electricity.

### 1. FIRST STAGE COALESCER CARTRIDGES

Your filter/separator is supplied with either threaded base or open-ended type coalescers depending on the purchase specification. The threaded base type has threads on one end and a blind cap on the other end. Open-end coalescers are open at both ends.

Open the shipping carton and break open the polyethylene bag at the threaded base end and slide the bag back a few inches. **Leave the bag on the cartridge for handling purposes during installation. AVOID TOUCHING THE OUTER SOCK MATERIAL WITH YOUR HANDS OR ANY GREASY MATERIALS.**

#### A. Threaded Base Coalescers

- (1) Thread each coalescer by hand onto the adapter that is installed in the vessel until you feel the gasket seat on the adapter knife-edge.
- (2) Turn the cartridge with both hands until hand tight and slowly remove the polyethylene bag.
- (3) After coalescers have been threaded securely in place, use a special Gammon Technical Products Inc. adapter (GTP-1224) on the square fittings on the ends of the coalescers to tighten to

30 ft-lbs torque.

- (4) Go to Step 2, **SEPARATOR CARTRIDGES**, and continue.

B. Open End Coalescers

- (1) Ensure tie rods are securely mounted. If not installed, refer to Tie Rod Installation Instruction for details.
- (2) Install coalescer cartridges carefully so that they seat around the pilot guides on the mounting adapters.
- (3) Slowly remove polyethylene bags and install the end seal plates on tie rods and coalescers.
- (4) Install rubber gasket (P/N G-0305), flat washer (P/N K06), lock washer (P/N K05), and nut (P/N K07) on each tie rod, in that order.
- (5) Hand tighten the nuts and then use a wrench to tighten it to 5 ft-lbs torque. **DO NOT OVER TORQUE.**
- (6) Place one large diameter flat washer (P/N K08) over each threaded stud on threaded base coalescers or over tie rod of open end coalescers ( P/N K87)
- (7) If initially installing thread a 3/8" nut (P/N K07) over each coalescer spider mounting stud and spin down to approximately the end of the coalescer. Slip a 3/8" flat washer (P/N K06) over each mounting stud and atop the nut.
- (8) Install the coalescer spider over the coalescer studs, or tie rods, over the coalescer spider mounting studs and push down as far as possible. If initially installing adjust the nuts on the coalescer spider mounting studs upward until the flat washer contacts the underside of the spider.
- (9) Install another flat washer (P/N K08 or K87) on each coalescer stud, or tie rod, atop the spider. Install spider hold down nuts on each coalescer stud (use P/N K02) or tie rod (use P/N K07) and tighten to 5 ft-lbs.  
  
At each spider mounting stud, install a flat washer (P/N K06), then a locking washer (P/N K05) and finally a hex nut (P/N K07) and tighten to 5 ft-lbs.
- (10) Inspect installation of coalescers and spider to verify the coalescers are equally spaced and not in contact with other cartridges or

the vessel walls and adjust accordingly. Failure to do so may result in poor water removal efficiency.

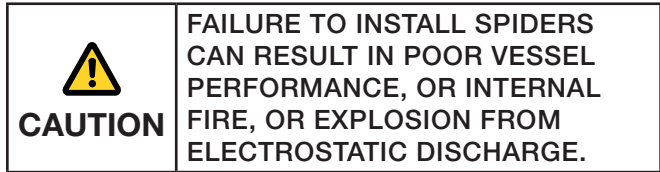

2. **SEPARATOR CARTRIDGES**

Your filter/separator will be supplied with either PTFE coated screen, synthetic, or paper media separators depending on the purchase specifications. Separator cartridges should be removed inspected, cleaned, or replaced at the same time the coalescer cartridges are changed.

- A. PTFE Coated Separators are re-usable with proper maintenance. Synthetic media separators can be cleaned and re-used a maximum of 2 times (see Appendix H).
- B. Paper Separator Cartridges need replacement after one year of operation or if contaminant or discoloration is observed on the media. Replace both paper separator and coalescer cartridges if effluent fuel is hazy.

Follow the same unpacking procedure as outlined above for the coalescer cartridges. Break the polyethylene bag open but leave the bag in place for handling during installation.

**DO NOT TOUCH THE SURFACE OF THE SEPARATOR MEDIA.**

- (1) Ensure tie rods are securely mounted. Refer to Tie Rod Installation Instruction for installation details if required.
- (2) Install separator cartridges carefully so the cartridges are properly seated around the pilot guides on the mounting adapters.
- (3) Slowly remove polyethylene bags.
- (4) On horizontal vessels, rotate the separators so that the overlap seams will not trap water.
- (5) Install separator cartridge hardware as follows:
  - (a) If the separator cartridge has integral end caps, locate separator seal nut (P/N K20A), verify the O-Ring (P/N G-1089) is in place in the groove then thread down onto tie rod. Verify the o-ring contacts the cartridge; adjust the tie rod if required. Tighten to



- 5 ft-lbs. Slip 5/8" flat washer (P/N K18) over separator seal nut. Repeat for all separators.
- (b) If the separator cartridge has open end caps, slip end seal cap over the tie rod and guide into the opening in the end of the cartridge. Make sure the guide slips down inside the cartridge and the knife edge contacts the cartridge's gasket. Install rubber seal washer (P/N G-0305), flat washer (P/N K06), lock washer (P/N K05) and nut (P/N K07) on tie rod, in that order, and tighten nut to 5 ft-lbs. Slip large flat washer (P/N K08) over the tie rod, atop the nut. Repeat for each separator.
- (c) If the seal cap is a 12-02C, a K20A maybe used, refer to 5(a) above for hardware and torque.
- (6) If initially installing, thread a 3/8" nut (P/N K07) over each separator spider mounting stud and spin down to approximately the end of the separator cartridge. Slip a 3/8" flat washer (P/N K06) over each spider mounting stud and locate atop the nuts.
- (7) Install the separator spider over the separator tie rods or seal nuts and over the separator spider mounting studs and push down as far as possible. If initially installing, adjust the nuts on the separator spider mounting studs upward until the flat washer contacts the underside of the separator spider.
- (8) Install another large flat washer (P/N K18 or K08) over each separator tie rod or seal nut. Install a spider hold down nut over the seal nut (use P/N K19) on the tie rod (use P/N K07) and tighten down to 5 ft-lbs.
- (9) At each separator spider mounting stud install a flat washer (P/N K06), a lock washer (P/N K05) and a nut (P/N K07) and tighten to 5 ft-lbs.
- (10) Inspect completed separator hardware installation and verify the separators are equally spaced and do not contact other cartridges or the vessel walls and adjust accordingly. Failure to do so may result in poor water removal efficiency.

 <b>CAUTION</b>	<p><b>FAILURE TO INSTALL SPIDERS CAN RESULT IN POOR VESSEL PERFORMANCE OR INTERNAL FIRE OR EXPLOSION FROM ELECTROSTATIC DISCHARGE.</b></p> <p><b>USE ONLY VELCON CARTRIDGES IN THIS FILTER/SEPARATOR. VELCON CANNOT WARRANTY PERFORMANCE IF ANY OTHER MANUFACTURER CARTRIDGES ARE USED.</b></p>
---	---

### OPERATING INFORMATION

Below are the Parker AFD recommendations for operating procedures. Your company maintenance and/or quality control procedures may provide alternate instructions on these matters.

1. **COALESCER CARTRIDGES** should be changed in accordance with one of the following, whichever comes first:
  - A. When the differential pressure reaches the level specified on the cover page of this manual.
  - B. After an operating period of one year, if the recommended differential pressure limit has not been reached.
  - C. Whenever effluent product is hazy.
2. **SEPARATOR CARTRIDGES** should be inspected and cleaned or changed in accordance with Separator Cartridge instructions on page 7.
3. **DIFFERENTIAL PRESSURE READINGS**  
Differential pressure is the difference between the pressures upstream and downstream of the filter/separator. Differential pressure increases when contaminant is filtered by the first stage coalescers and causes flow restriction.

Readings should be taken when the system is flowing at maximum capacity. For differential pressure taken at less than maximum flow see Appendix F.

If the filter/separator is equipped with a direct reading differential pressure gauge, the reading shown on the gauge is the differential pressure across the filter/separator.

If the filter/separator is equipped with a pressure gauge and a selector valve, use the following procedure for determining differential pressure:



- A. Turn the handle one way and record the pressure reading.
- B. Turn the handle the other way (90° or 180°, depending on the type of valve) and record the pressure reading.
- C. Subtract the lower reading from the higher reading to determine differential pressure. The higher reading is inlet pressure.

<b>NOTE</b>	<p>If this filter/separator is installed on mobile equipment, the pressure gauge has probably been supplied and installed by the Vehicle Builder and may require a different procedure for determining differential pressure. If there is no pressure gauge listed in the Accessory Parts List of the manual, check other operating literature supplied by the Vehicle Builder for alternate instructions.</p> <p>Differential pressure readings should be taken at least once during every operating week and more frequently in high throughput installations or when the differential is increasing rapidly. Records of the differential pressure and throughput should be maintained to determine when cartridges should be changed.</p>
-------------	--

A sudden drop in pressure differential is an indication of a possible problem. Check first to be sure readings were taken at equivalent flow rates. If so, shut the system down, open the filter/separator, and inspect the following:

- A. Ruptured Cartridges. See if any of the coalescers ruptured as indicated by the outer sock cover having a ballooned appearance.
- B. Ruptured O-ring Seals. Check to see that all o-ring seals and gaskets are in place and have the same alignment as when the cartridges and parts were installed.
- C. Broken End Plates. Inspect all of the end plates of the cartridges.
- D. If any of the above are observed, check the system for possible hydraulic shock conditions. If the system is not provided with adequate surge controls, the sudden start-up of a high-pressure pump can create extremely high shock loads that may exceed the design of these components.

A reduction in pressure differential without a failure as indicated above is possible. This occurs if dry product has been handled for a long period of time and contaminant build-up is in the primary filtration layers of the coalescer cartridge. If wet product hits this contaminant build-up it will break up the large agglomerated particles into small individual particles and penetrate deeper into the cartridge. This will cause a drop in the pressure differential, but in no case should it go below the pressure differential recorded when the cartridges were installed.

#### CARTRIDGE CHANGE OR INSPECTION PROCEDURE

1. Shut off the pump.
2. Turn off the electric heater if the filter/separator is equipped with one.
3. Close the inlet and outlet pipe valves.
4. Open the drain valve and remove the product from the filter/separator

<b>NOTE</b>	<p><b>ON VERTICAL VESSELS WITH 2 DRAIN VALVES, DRAIN COMPLETELY FROM THE MAIN COMPARTMENT (WATER DRAIN) VALVE, THEN A FEW GALLONS FROM THE INLET COMPARTMENT (DIRTY DRAIN) VALVE.</b></p>
-------------	---

5. Open the manual top air vent valve. This will permit the unit to drain.
6. Open the cover and inspect the cover gasket—replace the gasket if it is damaged.
7. Remove coalescer and separator spiders and their associated hardware and set to one side for reinstallation.
8. Remove coalescer cartridges and dispose of in an appropriate manner. Remove, inspect, and clean the separator cartridges in accordance with separator cartridge instructions on page 14 and Appendix H.
9. Wipe off with a clean lint free rag or wash down with clean fuel any foreign matter from the vessel interior and from the spiders.
10. Install the cartridges and spiders in accordance with instructions on pages 12 and 13, also see Appendix B.

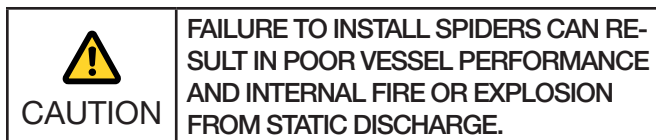

11. Check the cover gasket for integrity and alignment, replace the cover, and secure tightly. Refer to Torque Requirements for Vessel Closures Installation Instruction on page 15 for appropriate torque values and tightening sequence. The filter/separator is now ready for the start-up procedure.

### SUMP CHECKS

Whether or not the filter/separator is equipped with an automatic drain valve, the sump should be manually drained on a regular basis to remove any collected water. This should be done at least once each operating day and more often, if required, to prevent water carryover. Aircraft Fueling Regulations will govern the frequency of sump checks for aircraft equipment.

Draining, or sump sampling, should be done when the vessel is fully pressurized, preferably when fuel flow through the vessel is at its maximum. This will provide velocity to move collected water to the drain valve, and will also prevent air from entering the vessel. Carefully open the drain valve as far as possible without causing spillage. Drain off into a white bucket or other suitable container until all water is removed and clean, dry fuel is obtained. Even small quantities of water should be kept drained from kerosene or diesel products to prevent microbial growth at the fuel/water interface. Perform appropriate fuel appearance tests of the drained sample and record all findings. Remove the vessel from service if unable to obtain clean, dry fuel. Report any unusual contamination to aircraft operators if it is anticipated that such contamination may impact aircraft operations.

<b>NOTE</b>	VELCON DOES NOT RECOMMEND, WARRANTY, OR SELL AUTOMATIC DRAIN VALVES. The automatic drains valves can often malfunction and result in draining the fuel tanks completely onto the ground. Resulting in costly environmental cleanup, subsequent environmental problems, and fuel replacement costs.
-------------	--

To reorder cartridges and replacement parts or to obtain further information, contact your Parker AFD representative:

Parker Hannifin Corporation  
 Filtration Group  
 Aerospace Filtration Division  
 1210 Garden of the Gods Road  
 Colorado Springs, CO 80907-3410

Tel: +1 719 531 5855  
 Fax: +1 719 531 5690  
 vfsales@parker.com  
[www.velcon.com](http://www.velcon.com) | [www.parker.com](http://www.parker.com)

# Installation Instructions

## Threaded Base Cartridges

1. Turn off the pump. Close inlet and outlet valves to the housing.
2. Open the top vent and drain the housing through the bottom drain. Drain a few gallons out of the inlet compartment dirty drain if so equipped.
3. Loosen the bolts and swing away/remove the cover.
4. Remove the spider (if installed); remove all cartridges.
5. Inspect the inside of the housing and wipe it clean if necessary.
6. The cartridges are packaged in individual poly-bags (the anti-static poly-bag protects the cartridge from being disarmed by handling, and prevents build up of static charge to cartridge). Cut the bag at the threaded base end and slide it back a few inches. **DO NOT TOUCH THE OUTER SOCK/MEDIA.**
7. Hold the cartridge with the poly-bag still protecting the cartridge or by the endcaps only if no bag and place it over the threaded base adapter. Screw on hand tight.
8. Remove the poly-bag **SLOWLY** from the cartridge after it is in place.
9. For 4 inch diameter cartridges, tighten to 15 ft-lbs of torque or hand tight. For 6 inch diameter cartridges, tighten to 30 ft-lbs of torque (about ¼-turn past hand tight). It is preferable to use a special Gammon Technical Products part number GTP-1224 four-sided adapter to do this. (DO NOT touch the outer sock.)
10. Make sure that no poly-bags remain in the housing. (If spider is not included proceed to step #11.) Replace the spider as follows:
  - Install the flat washer over each cartridge end and install the spider over the ends of the cartridges.
  - Affix the spider to the threaded clips on the vessel walls using the nut and lockwasher.
  - Adjust the spider clip nuts, so the spider lies flat on the ends of the cartridges
  - Install the washer and nut over the ends of the cartridges, to affix the spider to the cartridge ends. Snug the nuts. **DO NOT TIGHTEN YET.**
  - Adjust the ends of each cartridge to create even separation between the cartridges and between the cartridge and vessel wall. Cartridges should **NOT** be touching each other, nor touching the

vessel wall. The ends of the cartridges can be shifted within the spider plate holes as follows:

Cartridge Length	Shift Within the Spider Hole
Greater than 33"	Full movement within the spider hole
30"	Less than 5/8" (16 mm)
28"	Less than 9/16" (14 mm)
24"	Less than 1/2" (12 mm)
22"	Less than 1/2" (12 mm)
20"	Less than 3/8" (10 mm)
18"	Less than 3/8" (10 mm)
16"	Less than 5/16" (8 mm)
14"	Less than 1/4" (6 mm)
11"	Less than 3/16" (5 mm)
9"	Less than 3/16" (5 mm)

- When the cartridges are spaced properly, tighten the spider nuts to 5 ft-lbs.
11. Inspect the cover gasket and replace it if necessary. Tighten the cover securely in a cross-pattern process. Follow the procedures on page 15.
  12. Close the bottom drain valve and start the system pump.
  13. With the outlet valve closed, slightly open the inlet valve and allow the vessel to fill **SLOWLY** with fuel until the air eliminator closes or fluid begins to flow from the manual air vent. Close the vent valve. Fully open the inlet valve.
  14. Open the outlet valve **SLOWLY**.
  15. When the unit is operating, check the differential pressure across the cartridges. There should be indication of positive pressure, normally 1-5 psid. This ensures all seals have been properly placed during the installation.

### OPERATING PROCEDURES

Parker AFD recommended cartridge changeout

(Please also check with your company's fuel handling guidelines and operating procedures.)

Coalescer cartridges: one (1) year or 15 psid, whichever occurs first

## Open-End Coalescer Cartridges

1. Turn off the pump. Close inlet and outlet valves to the filter.
2. Open the air eliminator or manual air vent valve and drain the vessel through the bottom drain. Also drain a few gallons out of the inlet compartment "dirty" drain.
3. Loosen the bolts and swing the cover back.
4. Remove the spider (if installed) and then remove the old cartridges from the vessel.
5. Cut the new cartridges' protective poly-bags at both ends.
6. Holding the new cartridge with the poly-bag still protecting the cartridge, place it over the tie rod. (The poly-bag protects the cartridge from being disarmed by handling.) Make sure the cartridge seats against the mounting adapter. **DO NOT TOUCH THE OUTER SOCK.**
7. Remove the poly-bag **SLOWLY** from the cartridge after it is properly seated.
8. If open-end cartridges are stacked, insert a center spacer over the tie rod and seat it on the cartridge just installed. Install next cartridge over the spacer as per step 6. Be sure cartridge is properly seated.
9. Place the end seal plate over the rod and seat onto top of cartridge.
10. Place the rubber gasket, flat washer, lock washer, and nut on the rod and tighten down hand tight. (Use the new rubber gasket in the plastic bag supplied with the cartridge.)
11. Torque the nut to 5 ft-lbs of torque (or until the rubber gasket starts to spread and curl up). Repeat steps 5-11 until all cartridges are installed.
12. If supplied, install the spider plate over the ends of the cartridges. Before tightening bolts ensure proper spacing between the cartridges. Cartridges should not touch each other or the vessel wall. The ends of the cartridges can be shifted within the spider plates holes as follows:

Cartridge Length	Shift Within the Spider Hole
Greater than 33"	Full movement within the spider hole
30"	Less than 5/8" (16 mm)
28"	Less than 9/16" (14 mm)
24"	Less than 1/2" (12 mm)
22"	Less than 1/2" (12 mm)
20"	Less than 3/8" (10 mm)
18"	Less than 3/8" (10 mm)
16"	Less than 5/16" (8 mm)
14"	Less than 1/4" (6 mm)
11"	Less than 3/16" (5 mm)
9"	Less than 3/16" (5 mm)

13. Adjust the spider clip nuts, so the spider lies flat on the ends of the cartridges. When the cartridges are properly spaced, tighten the spider nuts to 5 ft-lbs.
14. Making sure no poly-bags remain in the vessel, replace cover and tighten securely. Follow procedures listed on Bulletin 1935, on back of this form.
15. Close the bottom drain valve and start the system pump.
16. Open the inlet valve slightly. Keep the outlet valve closed.
17. Allow the filter to fill **SLOWLY** with the fuel until the air eliminator closes. If a manual air vent is on the unit, allow to fill **SLOWLY** until fuel comes out of vent valve, then close the vent valve.
18. When vessel is full, open the inlet valve fully, then slowly open the outlet valve.
19. While the unit is operating, check the pressure drop across the elements. There should be some indication of a positive pressure, normally 1-5 psid. This ensures that all seals have been properly made during the installation.

### OPERATING PROCEDURES

Parker AFD recommended cartridge changeout

(Also refer to your company guidelines)

Coalescer cartridges: one (1) year or 15 psid, whichever occurs first

## Separator Cartridges

1. Turn off the pump. Close the inlet and outlet valves to the filter/separator vessel.
2. Open the air eliminator or manual vent valve and drain the vessel through the bottom drain.
3. Open the vessel and remove the old separator cartridges.
4. Cut the new cartridge's protective poly-bag at both ends.
5. Holding the new cartridge with the poly-bag still protecting the cartridge, place the cartridge over the tie-rod. (The poly-bag protects the cartridges from being disarmed by handling.) **DO NOT TOUCH THE SEPARATOR MEDIA.** [Separators should be installed after the coalescers are installed, to prevent damage to the separators.]
6. Remove the poly-bag slowly from the cartridge after it is in place.
7. Place the end cap over the tie-rod. (Not needed on SO-3xxV, SO-4xxV, SO-6xxVA, SO-6xxV and SO-6xxPV separators which have blind end cap already affixed.)
8. Place the new flat gasket over the tie rod. Discard the old gasket.\*
9. Place the flat washer, lock washer, and nut over the tie rod and tighten to 3-5 foot-pounds of torque. (Lockwasher will be flat).\*
10. Make sure separators are evenly spaced and not touching each other or the vessel wall by following these steps.
11. Make sure that no poly-bags remain in the housing, then replace the spider as follows:
  - Install the flat washer over each cartridge end and install the spider over the ends of the cartridges.
  - Affix the spider to the threaded clips on the vessel walls using the nut and lockwasher.
  - Adjust the spider clip nuts, so the spider lies flat on the ends of the cartridges
  - Install the washer and nut over the ends of the cartridges, to affix the spider to the cartridge ends. Snug the nuts. **DO NOT TIGHTEN YET.**
  - Adjust the ends of each cartridge to create even separation between the cartridges and between the cartridge and vessel wall. Cartridges should **NOT** be touching each other, nor touching the vessel wall. The ends of the cartridges can be shifted within the spider plate holes as follows:

Cartridge Length	Shift Within the Spider Hole
Greater than 33"	Full movement within the spider hole
30"	Less than 5/8" (16 mm)
28"	Less than 9/16" (14 mm)
24"	Less than 1/2" (12 mm)
22"	Less than 1/2" (12 mm)
20"	Less than 3/8" (10 mm)
18"	Less than 3/8" (10 mm)
16"	Less than 5/16" (8 mm)
14"	Less than 1/4" (6 mm)
11"	Less than 3/16" (5 mm)
9"	Less than 3/16" (5 mm)

- When the cartridges are spaced properly, tighten the spider nuts to 5 ft-lbs.
12. Inspect the cover gasket and replace it if necessary. Tighten the cover securely in a cross-pattern process. Follow procedures listed on Bulletin 1935.
  13. Close the bottom drain valve and start the system pump.
  14. With the outlet valve closed, slightly open the inlet valve and allow the vessel to fill SLOWLY with fuel until the air eliminator closes or fluid begins to flow from the manual air vent. Close the vent valve. Fully open the inlet valve. Open the outlet valve SLOWLY.
  15. When the unit is operating, check the differential pressure across the cartridges. There should be indication of positive pressure, normally 1-5 psid. This ensures that all seals have been properly made during the installation.
  16. See Form VEL1242 for PTFE Coated Screen Separator Cleaning Instructions. **OPERATING PROCEDURES**

*\* As a recommended alternative to the flat gasket, washers, and nut when using 3/8" diameter tie rods, Velcon offers part number K20A separator seal nut. This has an O-ring in its base to provide the seal. Tighten to 5 ft-lbs of torque.*

**PLEASE NOTE: The normal shelf life for pleated paper separators (for example, SO-xxxPLF3 and SO-6xxPLBZ) is ONE YEAR from the date of manufacture.**

However, pleated paper separators can be used beyond the one year shelf life and will work properly providing they have been kept clean and dry, and stored in their original poly bags and boxes. Before installing pleated paper separators, closely examine the separator media for any damage that may have occurred during storage or handling. Contact Velcon if you have any questions.



## Torque Requirements for Vessels with O-ring Closure

Bolted pressure vessel closures operate on the premise that the joint is clamped closed with a force sufficient to resist the internal pressure yet still maintain a seal. The clamping force, or pre-load, is applied by the closure bolts and its magnitude is controlled by the torque applied. Application of the correct preload is essential to maintaining a positive seal and avoiding closure failures from fatigue or overstressed vessel components.

The short term, and most obvious effect of grossly under-torqued bolts is insufficient clamping force resulting in a leaking closure. A more ominous result of under-torqued bolts in systems which see a great number of pressure cycles (such as refuelers, loading racks etc.), is bolt fatigue failure. Repeated applications of stress to the bolt eventually create a small crack at the surface of the bolt which continues to grow until the bolt breaks and the closure fails.

It is a good idea to re-torque the closure bolts after they have been in use for a month or so to ensure the joint has not “relaxed” and the preload reduced.

Over-torquing closure bolts will result in breaking or bending vessel bolt clips or actually breaking the bolt itself. Table One lists guideline torque values for lubricated bolts for common sizes used for vessel closures. Always use lubricated bolts, as this reduces the required torque, improves torque accuracy, and retards corrosion.

A common cause of inaccurate bolt torque is inappropriate bolt torquing procedures. Key elements to the procedure are application of the torque in stages and in a specific cross-torquing sequence. For most applications, torque is applied to all bolts to 30% of full torque, then to all bolts to 60% of full torque, and finally to all bolts to 100% of full torque. Each torquing cycle is carried out in the applicable cross-torquing sequence. Torquing sequences vary with the number of bolts on the cover.

The tightening pattern is as follows: Tighten two bolts diametrically opposite from each other, then tighten a second pair of bolts diametrically opposite each other, approximately 90 degrees away from the first pair, and so on until all bolts have been tightened.

Using a clock as an example, the sequence would be: 12 - 6, 9 - 3, 11 - 5, 10 - 4, 7 - 1, and 8 - 2.

On large vessels, the cross-torquing process is tedious but the addition of a second operator applying torque improves the situation vastly.

Correct closure torquing will result in many years of trouble-free vessel operation. Occasional inspections for bolt cracks or clip damage is good practice to detect possible closure problems before they occur.

**TABLE ONE\***

Bolt Diameter mm (in.)	Recommended Torque m-kgs (ft-lb)
13 (1/2)	3 (20)
19 (3/4)	6 (45)
25 (1)	14 (100)
32 (1-1/4)	22 (160)
38 (1-1/2)	36 (260)

\*NOTE: These recommended torque values are only for vessels with an o-ring closure.

## Tie Rods

### REFERENCE MATERIAL

Form 1801- "Assembly Torque Recommendations"

### VESSELS WITH TIE RODS

- Filter vessels
- Clay vessels
- Monitor vessels containing 6" Aquacon® cartridges
- Filter/separator vessels (for coalescer and separators)

### HARDWARE

- Tie rods
- Hardware (nuts, flat washers, lock washers, seal nuts)
- Cartridges
- Mounting adapters
- Center spacers
- End caps

### MOUNTING CONFIGURATIONS

- With spider
- Without spider
- With seal nut

### VERTICAL OR HORIZONTAL OPEN ENDED CARTRIDGES WITH SPIDER PLATE:

1. Screw a nut on one end of the tie rod to about 2" from the end (see note on bottom of page 2).
2. Slide a lock washer up against the nut on the short-ened side of the tie rod.
3. Slide a mounting adapter (on vessels with integral cast-in or welded-in mounting adapters, no additional adapter is required) on the short side of the tie rod with the cartridge seal side facing the nut and washer.
4. While holding the mounting adapter on the end of the rod, screw the short end of the tie rod into the tie rod bar on the vessel. Screw in about one inch.
5. Install a cartridge over the tie rod and into place on the mounting adapter.
6. If cartridges are stacked, install center spacers between cartridges.

7. Place an end seal plate on the top or end of the cartridge (or cartridge stack) with the tie rod extending out from the end seal plate tie rod hole.
8. Adjust the tie rod by screwing it in or out until the amount extending beyond the end cap is 1-5/8". Remove the cartridges, spacers, and caps.
9. Screw the nut at the end of the tie rod down against the mounting adapter while preventing the tie rod from turning.
10. Tighten the nut to 5 foot pounds of torque.
11. Install the other tie rods so that they extend out from the mounting adapters the same length as the first rod.

### VERTICAL OR HORIZONTAL OPEN ENDED CARTRIDGES WITH NO SPIDER PLATE:

1. Screw a nut on one end of the tie rod to about 2" from the end. (See note below.)
2. Slide a lock washer up against the nut on the short-ened side of the tie rod.
3. Slide a mounting adapter (on vessels with integral cast-in or welded-in mounting adapters, no additional adapter is required) on the short side of the tie rod with the cartridge seal side facing the nut and washer.
4. While holding the mounting adapter on the end of the rod, screw the short end of the tie rod into the tie rod bar on the vessel. Screw in about one inch.
5. Install a cartridge over the tie rod and into place on the mounting adapter.
6. If cartridges are stacked, install center spacers between cartridges.
7. Place an end seal plate on the top or end of the cartridge (or cartridge stack) with the tie rod extending out from the end seal plate tie rod hole.
8. Adjust the tie rod by screwing it in or out until the amount extending beyond the end seal plate is one (1) inch.
9. Remove the cartridges, spacers, and seal plates.

10. Screw the nut at the end of the tie rod down against the mounting adapter while preventing the tie rod from turning.
11. Tighten the nut to 5 foot pounds of torque.
12. Install the other tie rods so that they extend out from the mounting adapters the same length as the first rod.

**SEPARATOR WITH SEAL NUT (WITH OR WITHOUT SPIDER PLATE):**

1. Screw a nut on one end of the tie rod to about 2" from the end. (See note below.)
2. Slide a lock washer up against the nut on the shortened side of the tie rod.
3. Slide a mounting adapter (on vessels with integral cast-in or welded-in mounting adapters, no additional adapter is required) on the short side of the tie rod with the cartridge seal side facing the nut and washer.
4. While holding the mounting adapter on the end of the rod, screw the short end of the tie rod into the tie rod bar on the vessel. Screw in about one inch.
5. Install a separator over the tie rod and into place on the mounting adapter so the tie rod extends from the end seal cap tie rod hole.
6. On double open ended separators, place an end seal plate on the top or end of the separator, with the tie rod extending out from the end seal plate tie rod hole.
7. Adjust the tie rod by screwing it in or out until the amount extending beyond the end seal plate is one (1) inch.
8. Remove the cartridges, spacers, and seal plates.
9. Screw the nut at the end of the tie rod down against the mounting adapter while preventing the tie rod from turning.
10. Tighten the nut to 5 foot pounds of torque.
11. Install the other tie rods so that they extend out from the mounting adapters the same length as the first rod.



# Appendix/Accessories

## APPENDIX A: FUNCTION OF FILTER/SEPARATOR ACCESSORIES

- 1 Automatic Air Eliminator**  
Provides air vent to permit escape of trapped air during filling of vessel. When unit is completely filled with fuel, air eliminator automatically closes.
- 2 Check Valve**  
Prevents air from siphoning into the vessel through the air eliminator.
- 3 Pressure Relief Valve**  
This valve can be set to open at a desired pressure to exhaust excess pressure built up in the system, due to thermal expansion in a non-flow condition.
- 4 Coalescer Element**  
Designed to remove solid contaminants, to break the emulsion of water in the product into droplets, and to enlarge these droplets so that they will drop out of the product. The flow is from the inside to the outside of the coalescer.
- 5 Separator Element**  
Repels coalesced water droplets and prevents them from going downstream. The flow is from the outside to the inside.
- 6 Slug Valve**  
In the event of excessive water build-up, the slug valve, on signal from the float control, will shut down all flow through the system until excess water can be drained off. The slug valve can be provided with a rate-of-flow control which will prevent excessive flow rates through the filter/separator.
- 7 Sampling Probe**  
The purpose of the probe is to ensure that fuel samples are representative of the fuel in the pipe. The probe penetrates through the pipe coupling that is welded to the pipe. There is no possibility of rust and dirt that usually collects in stagnant pockets reaching the filter membrane test capsule.
- 8 Manual Drain**  
Opened daily to remove any accumulated water and to sample the fuel in the sump. This also helps to evaluate the condition of the coalescer. It is also opened to completely drain the vessel when changing elements.
- 9 Float Control**  
Rides the interface between fuel and water, and by its up and down movement, opens and closes ports to generate hydraulic signals to automatic valves. Velcon recommends the "ballast" type float control for easier checking of the integrity of the float ball.
- 10 Pressure Gauge**  
The direct reading differential pressure gauge is used to measure the pressure difference between the inlet and outlet of a filter/separator, thus providing an indication of element condition.

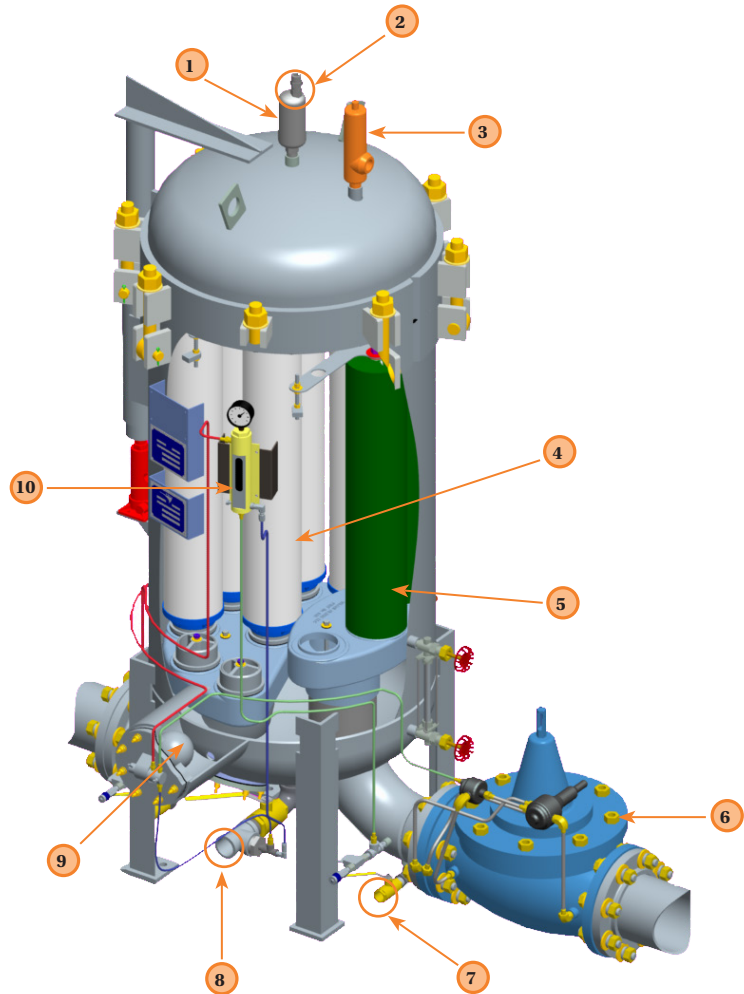



## APPENDIX B: THE IMPORTANCE OF SPIDERS

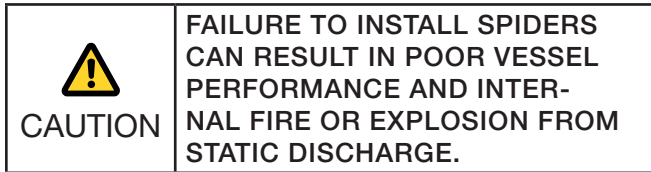

Spider plates (spiders) are an important part of a filter separator vessel. Spiders are usually made of aluminum or stainless steel, and may be rigid or open-mesh design. Spiders are fitted over the ends of various types of filter cartridges within the filter vessel.

There are five purposes for spiders in vessels:

1. To keep the cartridges separated in order to equalize flow around the cartridges, and to provide paths for the coalesced water drops to fall to the sump
2. To give support to the “free” ends of the cartridges (the ends not rigid against the deckplate)
3. To prevent microbial growth
4. To meet API/EI 1581 5th Edition or EI 1596 2nd Edition requirements
5. To prevent static discharge and internal fires

Keeping the coalescers (first stage cartridges) from touching each other enhances the coalescing process by giving room between the coalescers for the water to fully form into drops 1/8 to 1/4 inch in diameter, and then having room to fall by gravity to the sump at the bottom of the vessel.

It is very important to support the free ends of cartridges, particularly the heavy coalescers in horizontal vessels. Without a spider supporting the free ends, and without the spider being rigidly clamped or clipped to the vessel interior, the free ends can be exposed to heavy vibration which could eventually loosen the mounting ends leading to bypass, or even rupture the mounting.

Another reason to keep the coalescer socks from touching each other is to reduce the microbial growth area. Have you ever seen a light or dark grayish or blackish line running vertically down a coalescer? This is microbial growth.

API/EI 1581 5th Edition or EI 1596 2nd Edition Specification requires the use of spiders for cartridges longer than 18 inches (3.2.2.13) as well as certain minimum spacings between coalescers, separators (second stage cartridges), and between coalescer and separator within qualified vessels (3.2.2.15). To maintain such spacing a spider is required.

Spiders in the various vessels should not be allowed to become “unbonded charge collectors.” A solid electrical path from the spider to the vessel shell is essential. This can be accomplished through the tie rods that make solid

contact with the spider, or by contact with a metal clip attached to the side of the vessel. (Some filter/separator vessels have two spiders as shown in Fig. 1).

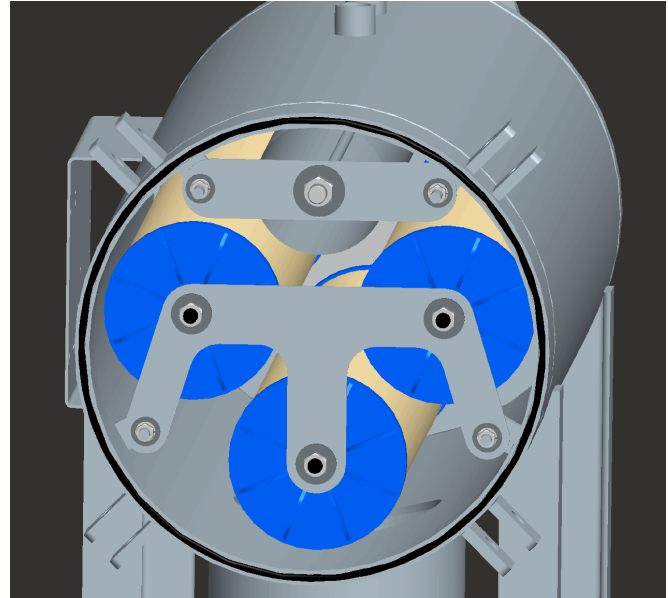

Figure 1. Two spiders in horizontal filter/separator bonded by clips to vessel.

The spider for the separators is electrically bonded to the tie rods that are bonded to the vessel. However, the other spider on the screw-base coalescers might not be bonded to anything (it thus becomes an “unbonded charge collector” which could lead to fires in the vessel). Ensure that these spiders are bonded electrically to the vessel by attaching to a metal clip, or by a braided stainless steel wire to the separator spider (see Fig. 2).

When converting a pre-filter (micronic) vessel from open-ended cartridges with tie rods to screw-base cartridges,

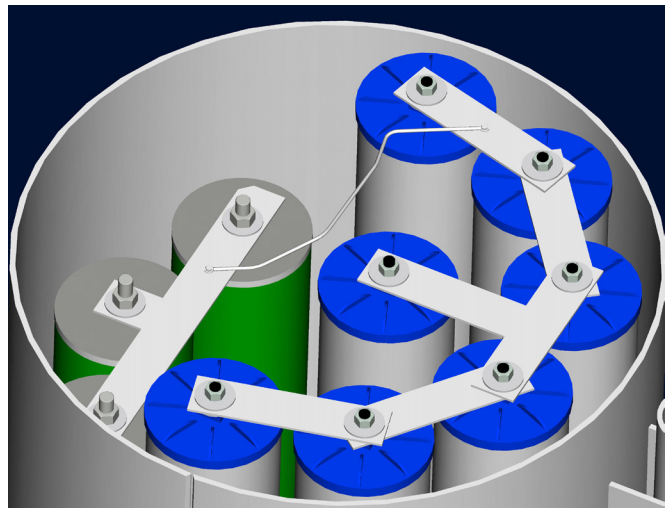

Figure 2. Two spiders in vertical filter/separator bonded together with braided stainless steel wire, bonded to vessel via separator tie-rods.

ensure the spider is somehow bonded to the vessel either by support clips on the vessel interior or by the braided stainless steel wire to the baffle plate (see Fig. 3).

A prefilter vessel with no internal baffle plate is a problem. The purpose of the baffle plate or angle iron is to divert flow



Figure 3. Spider on pre-filter bonded to baffle with braided stainless steel wire.

to the top of the vessel so the full flow does not all work against the nearest cartridges. Without the baffle plate, the nearest cartridges to the inlet can be torn apart.

## APPENDIX C: ASSEMBLY TORQUE SPECIFICATIONS

### COALESCER CARTRIDGES

<sup>1</sup>10 ft-lbs for I-4xxT coalescers

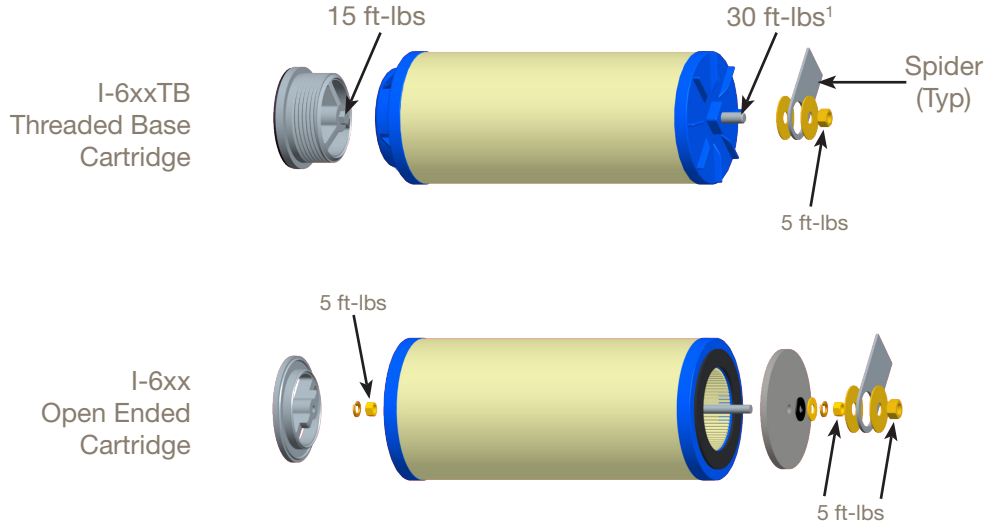

### SEPARATOR CARTRIDGES<sup>2</sup>

<sup>2</sup>All 3" and 4" separators should be torqued to 5 ft-lb on both ends.

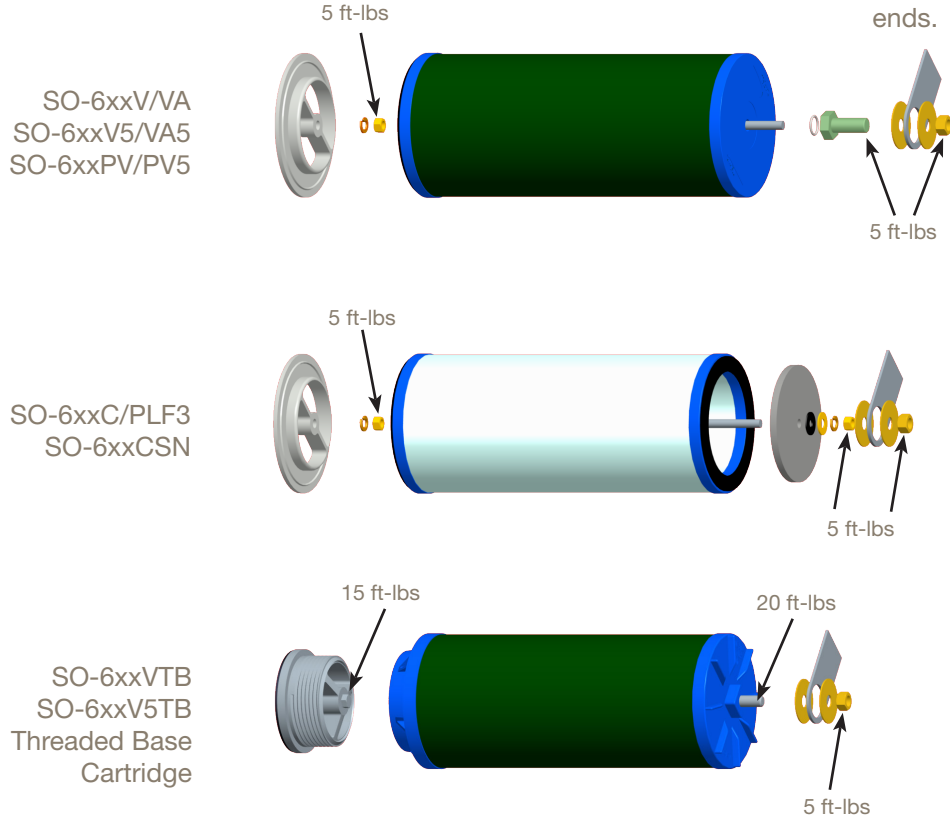

**FILTER CARTRIDGES**

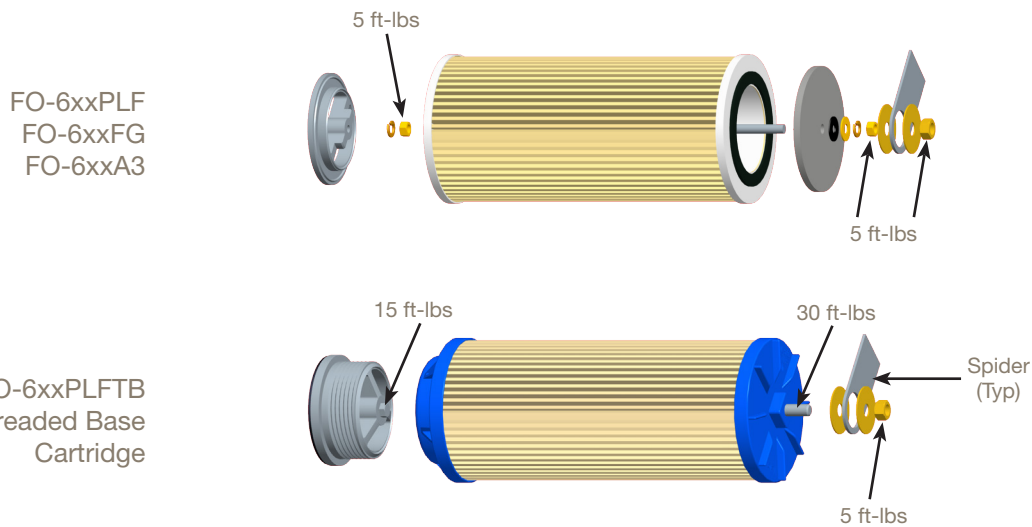

**Aquacon® CARTRIDGES**

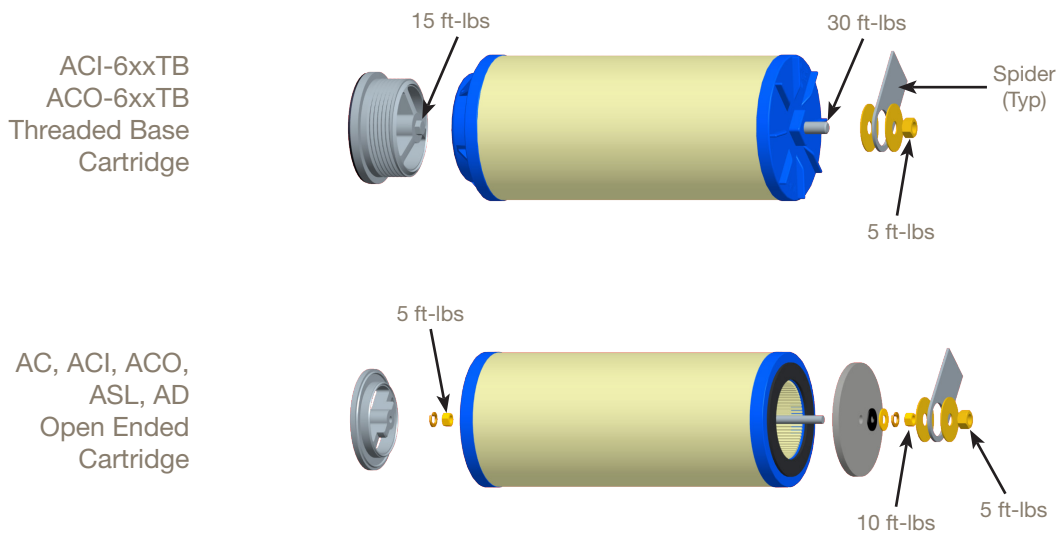

**TORQUE CONVERSION TABLE**

ft-lbs	inch-lbs	kg-m	N-m
5	60	0.69	6.78
10	120	1.38	13.56
15	180	2.07	20.34
20	240	2.77	27.12
30	360	4.15	40.67

## APPENDIX D: COALESCER FOR AVIATION FUEL USE

Coalescer cartridges are employed as the first stage in filter/separator vessels for hydrocarbon fluids. They perform two functions: (1) coalesce (combine) highly dispersed, emulsified water particles into larger water drops and (2) filter-out particulate contaminants.

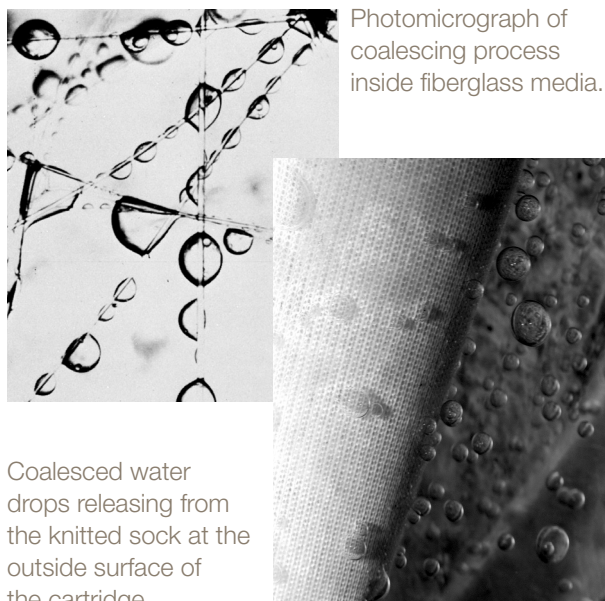

Photomicrograph of coalescing process inside fiberglass media.

Coalesced water drops releasing from the knitted sock at the outside surface of the cartridge.

### Product Features:

- Cost effective particle and emulsified water removal from hydrocarbon fluids
- Easy installation and replacement with one-piece design
- Choice of Threaded Base or Open End cartridges
- Choice of All-Fiberglass Media or Combination Fiberglass and Pleated Media
- Field proven performance
- Ongoing qualification testing to meet changing commercial and military requirements
- Used as a first-stage cartridge in filter/separators
- Remove particulates and coalesce water into large water drops
- Also available in screw base design

### Application

Coalescer cartridges are used primarily to coalesce emulsified water and remove particles from hydrocarbon fluids. The largest single application is the filtration of aviation jet fuel. They are also used with other types of fuels, process streams in refineries and petrochemical plants, and condensate streams where natural gas is produced.

Other liquids can be separated if they are immiscible, the specific gravities differ, and high concentrations of surface active agents are not present. As a rule of thumb, if a sample of the mixture readily separates in an hour or two, a coalescer can probably be used. If the mixture hasn't separated after 24 hours, coalescing probably won't work.

### Construction

Parker Velcon single-unit coalescer elements are offered with Threaded Base or Open Ends and with Fiberglass Media or Fiberglass and Pleated Media combinations.

Threaded Base Coalescers are recommended for use in most applications. They simplify installation and replacement by eliminating the need for cover plates, center plates, nuts, washers, and gaskets. They are for use in Velcon and other make filter/ separators. Threaded base adapters are available to convert vessels presently using open end elements.

Open End Coalescers are offered with single unit construction which reduces the number of gasket seals and improves overall reliability.

All-fiberglass Media Coalescers combine depth particulate filtration with a deep coalescing structure. All-fiberglass designs have successively finer media layers to achieve depth-type filtration of particles.

Combination Fiberglass and Pleated Media Coalescers remove particles primarily in the high surface area pleated core. They have one or more layers of pleated media inside a cylinder of molded fiberglass laminations to provide an extended surface area for particulate filtration. Pleat corrugation and separation materials are used to keep pleats open for full utilization.

Coalescing and filtration performance depends largely on the fiber diameter and bulk density of the fiberglass media. Both the All-Fiberglass and the Combination coalescer cartridge designs incorporate phenolic resin impregnated fiberglass media. Several grades with fiber diameters ranging from 1 to 10 micrometers are used in various combinations to achieve desired results. Velcon's latest coalescer designs (85, 87 and C5 series cartridges) achieve even higher filtration

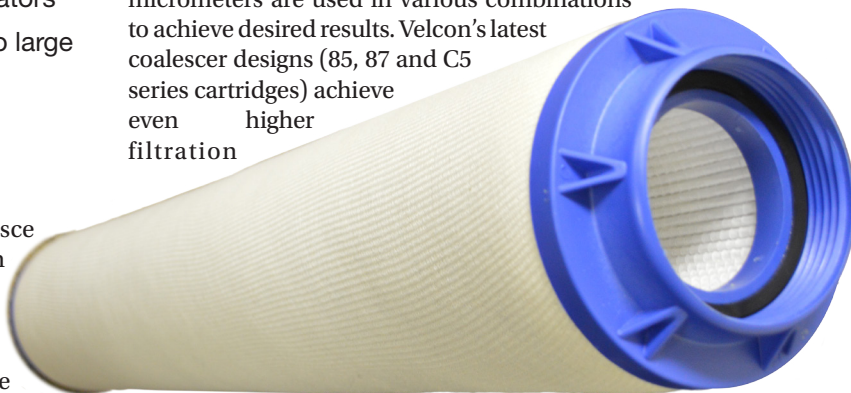



and coalescing efficiency by incorporating pure micro-glass fibers with diameters of less than 1 micrometer in the pleated media.

**Description**

**Model Number System.** Refer to the box at right. The one or two digit Series Designator relates to the approximate micron rating of each model coalescer cartridge. Note that this is a nominal rating and should be used for reference only.

The “0”, “2”, and “4” Series all-fiberglass cartridges are rated at 25, 5, and 3 microns respectively. The “2” and “4” Series are commonly used with diesel and other fuel oils, and are a compromise between filtration efficiency (cartridge life) and water removing capability. They coalesce gross water, but normally do not remove fine water haze.

The all-fiberglass “6” Series was originally developed for jet fuel service (the original MIL-F-8901 specification). With a 2-micron rating, it has proven to be the most cost effective design in some jet fuel applications. “6” Series cartridges are also used in gasoline filtration service. However, it should be noted that the powerful detergent additives in most automotive gasoline reduce the coalescing capability of this and other cartridge designs.

**“83” Series Cartridges.** The 1-micron rated “83” Series is a pleated media/fiberglass cartridge. The very practical “83” Series cartridges have become the most widely used design in applications including gasoline, condensate, and insulating oil filtration.

**“85” and “87” Series Cartridges.** The “85” Series is rated at 0.5-micron while the “87” Series is rated at 0.3 micron. Both incorporate multi-layered pleated media. The “85” Series has consistently shown superior dirt holding capacity in the field.

**JF5 Series Coalescers.** JF5 Series Cartridges are Parker AFD’s

newest design. Combined with V5N5 Series Separators, they offer higher flow rates and extended service life. See data sheet #1923 for more info.

EI\* 1581 6th Edition Cartridges. I-6xxC5 (TB), I-6xxMM, and I-6xxA4 Series of coalescers incorporate a multi-layered pleated media designed to provide superior dirt holding capacity in the field, combined with 0.4 micron efficiency. The I-6xxC5 (TB) replaces both the I-6xx85 (TB) and I-6xx87 (TB) cartridges. These cartridges are available in either threaded base or open-end configuration. See data sheets 1923 and 1934 for more specific information on EI 1581 6th Edition.

**Cartridge Dimensions.** 6” diameter cartridges are the current industry standard. They are offered in lengths of 11”, 14”, 22”, 28”, 33”, 38”, 44”, and 56”. However, not all series are available in all lengths or in both end cap designs. Contact your Velcon Distributor for details.

4” diameter cartridges are also offered for use with older equipment. They are available in a variety of lengths ranging from 8 to 40 inches.

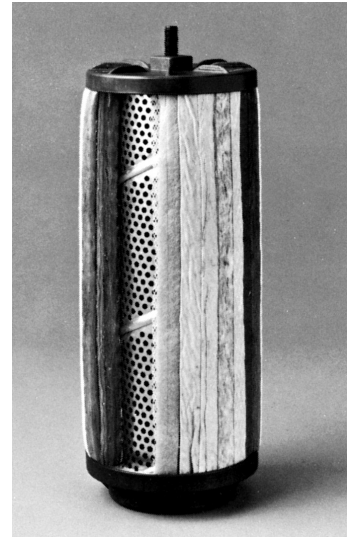

All-Fiberglass “6” Series Coalescer

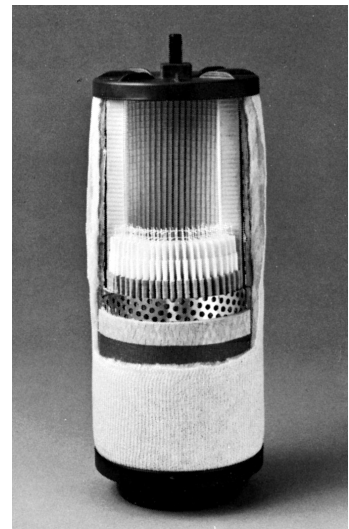

Fiberglass and Pleated Media “87” Series Coalescer



6” Diameter Threaded Base and Open End Coalescer End Caps



6000T Threaded Base Adapter



**Parker Velcon Coalescer Model Numbers**

Include significant product information.

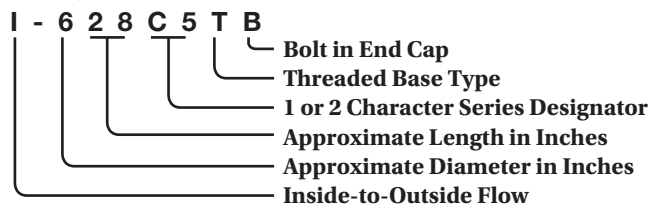
**Example:**

<b>NOTE</b>	I-628C5 would designate the open end version of this cartridge.
-------------	---

**General Specifications**

- 75 psi maximum pressure differential rating
- 5 to 9 pH range
- 150°–160°F max operating temperature
- Aluminum center tube
- Buna-N gaskets
- Injection molded end caps are standard on 6" diameter threaded base coalescers;
- Aluminum end caps are standard on 6" diameter open end cartridges
- All 6" diameter cartridge end caps are bonded directly to the media with high strength epoxy or urethane
- 4" diameter cartridge have molded polyester resin or injection molded end caps

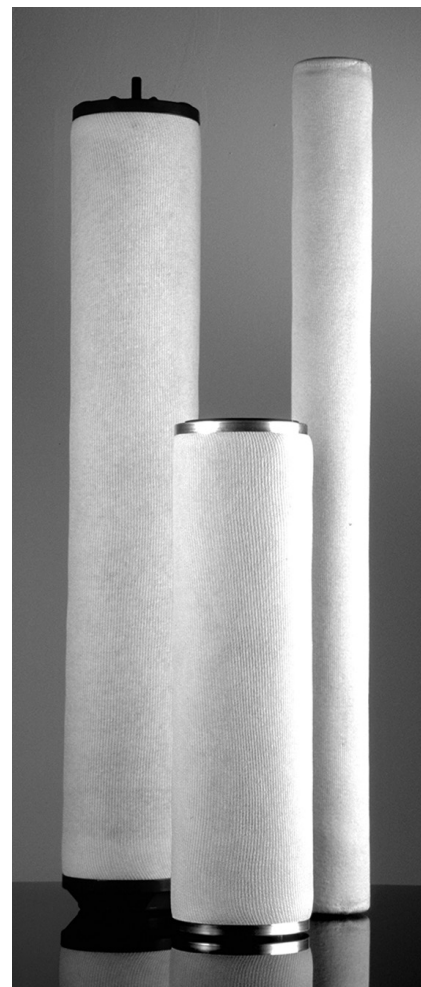

\*EI (Energy Institute) is the new specification authority. API (American Petroleum Institute) is no longer involved in aviation fuel filtration specifications.

**Vessel Selection Guidelines**

Aviation Fuel Filtration in commercial applications is governed by the complex, stringent requirements of EI 1581, 6<sup>th</sup> Edition. Refer to the appropriate Velcon literature or contact your Velcon Representative for assistance. For non-aviation applications the following guidelines have proven to be useful. Note, however, that these guidelines are general in nature and should be used for guidance only.

**1. Determine total length (inches) of 6” diameter cartridge required:**

- a. Find the approximate viscosity of your hydrocarbon fluid on the Chart Y-axis.
- b. Find the corresponding Specific Flow Rate (gpm/inch) on the X-axis.
- c. Divide Total Flow Rate (gpm) of your application by this Specific Flow Rate to calculate total inches of coalescer required.

**2. Select cartridge model and calculate quantity required:**

- a. Choose model (type and length) cartridge to use. 83 Series Coalescers are recommended for most applications. Other types and sizes are offered for special applications
- b. Calculate minimum number of cartridges required by dividing total inches (from Step 1) by length of cartridge selected.

**3. Select the Filter/separator Vessel for your application:**

- a. Refer to the Velcon literature for HV (horizontal) or VV (vertical) Filter/separators.
- b. Find the appropriate vessel for the model and quantity Coalescer Cartridge selected in Step 2.

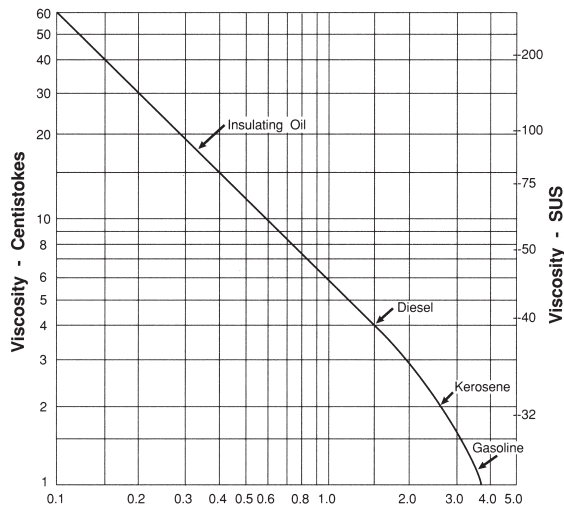

**Specific Flow Rate – gpm per inch of coalescer length for 6” diameter cartridges**

**NOTE** These guidelines assume a specific gravity of 0.92 or less, and an influent water concentration of 3% or less. In general, if the Interfacial Tension (IFT) of the hydrocarbon over water is 36 dynes per centimeter or greater, effluent water levels of 15 ppm or less can be achieved.

Surfactants will significantly lower IFT with a corresponding decrease in coalescing performance. Surfactants can occur naturally (diesel fuel) or they can be intentionally added as corrosion inhibitors (pipelines, lube and hydraulic oils) and detergent dispersants (automotive gasoline).

As previously discussed, diesel and fuel oils are a special category. 2 or 4 Series Coalescer Cartridges are commonly used. Pleated paper separator cartridges are typically specified since diesel often contains materials that adhere to TCS separators and cannot be cleaned off—nullifying the cost effectiveness. Refer to Velcon V Series filter/separator vessels literature.

Oversizing filtration equipment improves performance and extends cartridge life.

Strong bases (high pH fluids) attack glass microfibers and break down the coalescing media. Caustic washing or applications with high concentrations of MEA or DEA should be avoided.

Initial differential pressure (with clean coalescer cartridges) will be less than 5 psi. Cartridges should be changed when the differential pressure reaches 15 psi or after one year, whichever occurs first.

## APPENDIX E: DI & DSO Particulate and Water Removal from Diesel Fuel

As fuel is transported from the refinery to its point-of-use, it can quickly become contaminated from silica, pipe scale, and water condensate. These contaminants rapidly deteriorate fuel cleanliness far below engine manufacturers minimum for fuel cleanliness.

Velcon's DI coalescers in combination with DSO separators, contaminated fuels are cleaned to a level that meets stringent downstream fuel cleanliness standards for petroleum based diesel fuels.

The first stage in the DI coalescer removes particles through an inside-out flow and coalesces emulsified water into large droplets, which then fall to the housing sump. In the second stage, an outside-in process, the DSO separator creates a hydrophobic barrier to block the coalesced water droplets from flowing downstream of the housing. This multi-stage design assures the fuel is conditioned to a clean and dry state, ready for use.

### Tiered Ratings

- Parker Velcon 4 micron coalescer combines leading-edge particle removal with world-class coalescing technology to provide optimal fuel cleanliness
- The 10 and 25 micron rated filter coalescer provides effective particle removal with industry proven coalescing technology.

### Benefits

- Extended equipment up-time
- Reduced operating costs
- Reliable fuel injector performance
- Improved equipment up-time
- Reduced fuel system maintenance

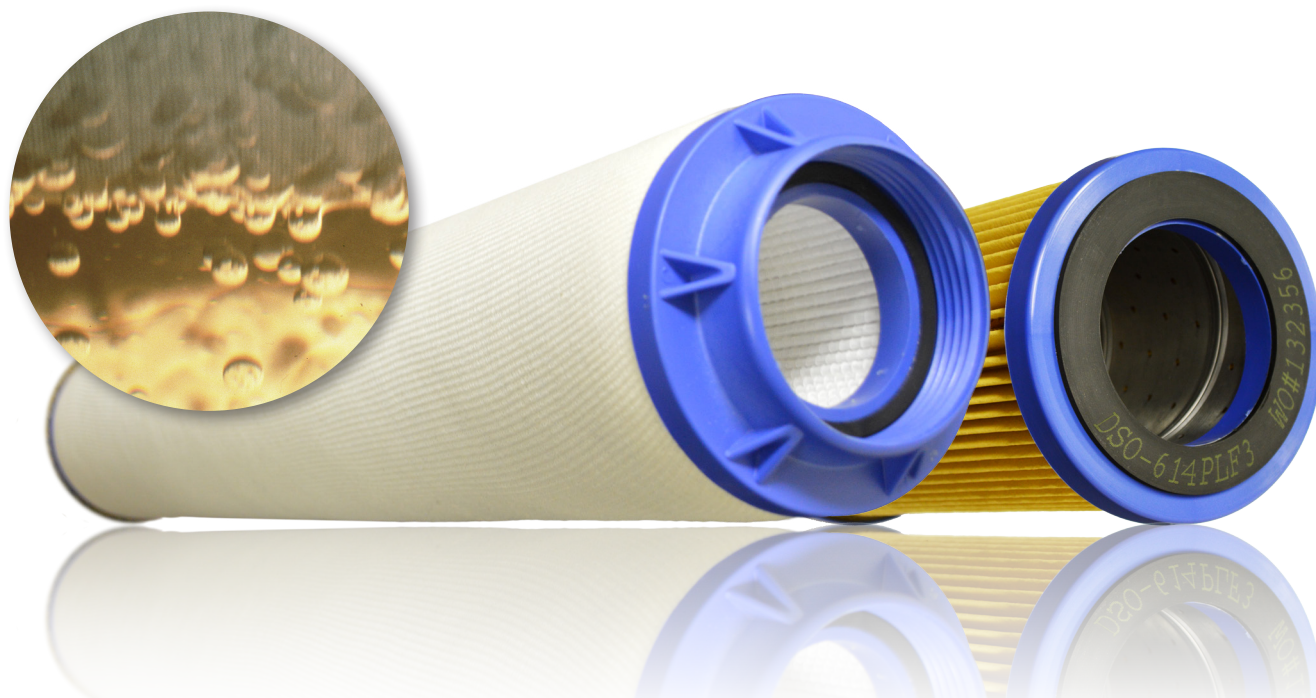

**Product Specifications**

- All filter components compatible with petroleum based diesel fuels
- Downstream free-water level typically below 50 ppm
- Recommended change out pressure: 25 psid (1.7 bar)
- Buna-N sealing materials standard
- Maximum operating temperature: 150°F (65°C)
- 6” (15.2 cm) outer diameter
- DI - coalescer flow direction - inside to outside
- DSO - separator flow direction - outside to inside

**Surfactants**

- Water coalescing is not effective in the presence of fuels containing high levels of surfactants/alcohols or unrefined biofuels
- Detergents and additives inhibits the ability of coalescers to effectively remove water by reducing Interfacial Tension (IFT) and can eventually disarm coalescers
- Contact Velcon Laboratories for further analysis of your fuel for presence of surfactants

**Recommended Housing**

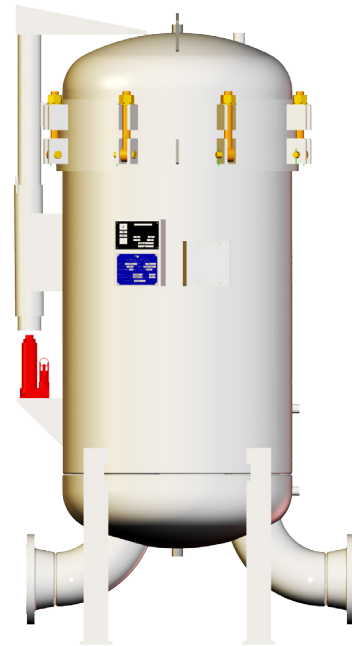

V Series  
 Filter-Coalescer/Separator

**DI Part Numbering**

Velcon recommends use of threaded base endcaps for ease of installation and to minimize components.

	O.D. in. (mm)	Length in. (mm)	Micron Rating (µm)	Endcap Options
<b>DI</b> -	<b>6</b> 6 (152)	<b>14</b> - 14 5/8 (371) <b>28</b> - 27 7/8 (709) <b>33</b> - 33 (838) <b>38</b> - 38 (965) <b>44</b> - 44 (1118) <b>56</b> - 56 (1422)	<b>D 4, 10, 25</b>	<b>S</b> (SOE) <b>V</b> (Viton Seal) <b>TB</b> (Threaded base)

Note: Other lengths and end fittings available. Please contact Velcon for further assistance.

*Example:*

**DI-628D25TB**

Variables that often change for the DI part numbers when placing an order are the length and the µm ratings; as seen in the case of the above example with the number 28 (length) and the number 25 (µm rating).

**DSO Part Numbering**

	O.D. in. (mm)	Length in. (mm)		Endcap Options
<b>DSO</b> -	<b>6</b> 6 (152)	<b>14</b> - 14 5/8 (371) <b>29</b> - 29 1/8 (737) <b>33</b> - 33 1/4 (914) <b>44</b> - 44 (1118)	<b>PLF3</b> (paper) <b>C</b> (screen)	<b>S</b> (SOE) <b>V</b> (Viton Seal)

Note: Other lengths and end fittings available. Please contact Velcon for further assistance.

*Example:*

**DSO-614PLF3**

Variables that often change for the DSO part numbers when placing an order are the length and the hydrophobic material. In the case of the above example with the number 14 (length) and the PLF3 (hydrophobic material) change.

## APPENDIX F: CARTRIDGE CHANGEOUT CURVE

Parker AFD recommends changing coalescer and monitor cartridges when the pressure differential reaches 15 psid and the filter/ separator is being operated at its rated flow. The system, however, will often be operating at lower flow rates with a corresponding lower differential pressure. If, for example, a 600 gpm filter/separator shows a differential of 12 psid at 300 gpm and the flow rate was increased to 600 gpm, the differential would be about 28 psid which is considerably above the recommended pressure drop for changing cartridges.

It is important, therefore, to know the pressure differential characteristics at lower flow rates for a set of coalescer cartridges which are plugged to the extent that they would show a 15 psid differential at rated flow. The graph below contains this information for Velcon cartridges.

**Vessel pressure drop characteristics for coalescer and monitor cartridges complying with ATA-103 guidelines.**

**EXAMPLES:** A 1000 gpm filter/separator is operating at 600 gpm, (60% of rated flow). If the pressure differential is less than 8 psid, the cartridges do not require changing. If the pressure differential is 8 psid or more, however, the elements are due for a changeout.

**EXCEPTION:** If the system in this example is limited to a maximum flow of 750 gpm by pump capacity or some other factor, then 750 gpm should be considered 100% of rated flow rather than higher rating of the filter/separator. In this case, the 600 gpm flow would be 80% of rated flow and the differential at this rate can be as high as 11½ psid without changing elements.

**NOTE** Stick-on decal of the below graph can be obtained by contacting Parker AFD at +1 719 531 5855 and asking to receive decal VEL1979. These labels can be affixed to the vessel near the differential pressure gauge.

**COALESCE AND MONITOR CARTRIDGE CHANGEOUT CURVE  
 FOR CARTRIDGES AT REDUCED FLOWRATES**

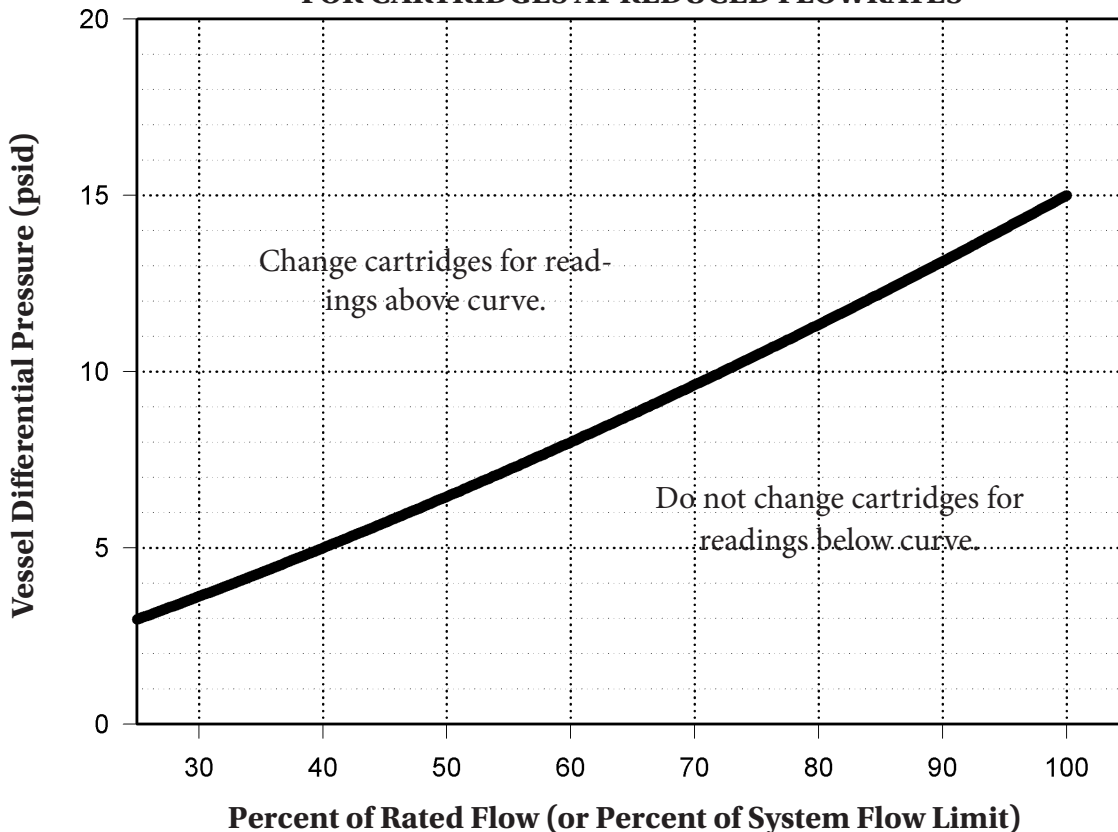



## APPENDIX G: SEPARATOR CARTRIDGES

### Features

- Optimum 2nd stage water removal
- Choice of PTFE Coated Screen, Synthetic or Pleated Paper Media
- Field proven performance
- Largest selection of replacement elements

### General

Separator Cartridges are employed as the second stage in filter/separator vessels. Their sole function is to repel coalesced water drops produced by the first stage cartridges while allowing hydrocarbon fluids to pass through. Water drops settle into the filter/separator sump and are not carried downstream. All particle filtering is done by the first stage coalescer cartridge.

### How Separator Cartridges Work

Flow direction is from outside-to-inside. The top photo insert shows water being repelled by the hydrophobic separator medium on the cartridge's outside surface. Hydrocarbon fluids, on the other hand, easily pass through and exit the separator cartridge. Cartridges with three different types of repelling media are offered:

**PTFE Coated Screen (TCS) Cartridges** are, by far, the most popular type of separator cartridge. With proper cleaning and inspection (see Velcon Form #1242), cost effective TCS elements can be reused over many changeout cycles. And, TCS cartridges generate considerably less static charge than pleated paper cartridges. These features have made them the preferred choice for aircraft fueling applications.

**Pleated Paper Cartridges** cannot be reused and are replaced at every coalescer cartridge changeout. They are often used with diesel and other fuel oils which may contain materials that adhere to TCS cartridges and cannot be cleaned off.

**Synthetic Media Cartridges** can be cleaned a maximum of two times. They are intended for customers who do not want to take the time to clean separators.

### Separator Cartridge Performance

Maintaining a uniform flow along the length of the cartridge optimizes performance and reduces the number of cartridges required. Flow is controlled by a tube, inside each cartridge, through which the hydrocarbon fluid exits the cartridge and the filter/separator vessel. Two styles of inner tube are offered. See bottom photo.

Cartridges with uniform hole pattern inner tubes are adequate for many applications. However, where optimum

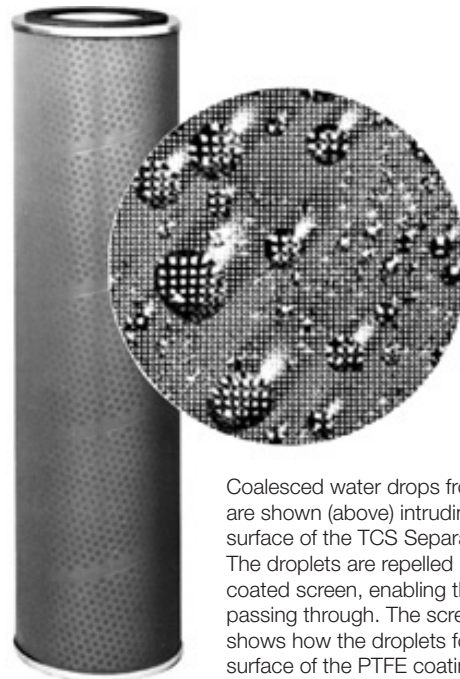

Coalesced water drops from the first stage are shown (above) intruding upon the surface of the TCS Separator Cartridge. The droplets are repelled by the PTFE coated screen, enabling the droplets from passing through. The screen magnification shows how the droplets form on the surface of the PTFE coating.

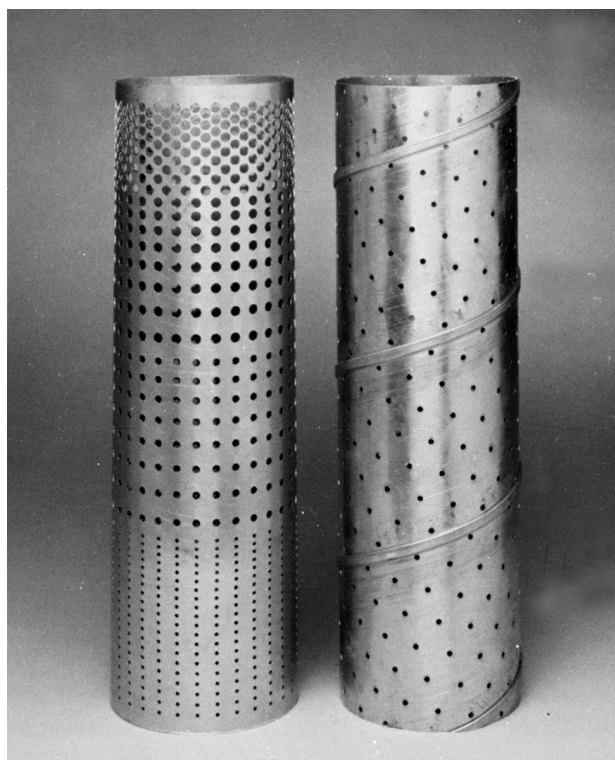

Variable Hole  
Pattern  
Inner Tube

Uniform Hole  
Pattern  
Inner Tube



flow distribution is required, cartridges with variable hole pattern inner tubes are recommended. When converting older equipment, a lesser number of variable hole pattern cartridges is usually required. Operating costs will therefore be reduced.

### Separator Cartridges

Model numbers containing a “C” in denotes a uniform hole pattern on the inner tube with TCS media, while the codes with a “V” signifies a variable hole pattern with TCS media. Blind caps have a hole for the tie rod.

### Parker Velcon Model Numbers

Include significant product information.

#### Example:

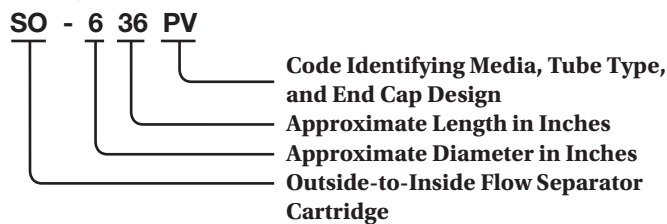

### Cartridge Code Identification

Model	Flow Control (hole pattern)	OD (in.)	Mounting	Opposite	Media
			End ID (in.)	End ID (in.)	
SO-3xxC	Uniform	3 $\frac{1}{16}$	2	Blind	TCS
SO-3xxV	Variable	3 $\frac{1}{16}$	2	Blind	TCS
SO-4xxC	Uniform	4 $\frac{1}{16}$	3 $\frac{1}{2}$	Blind	TCS
SO-4xxV	Variable	4 $\frac{1}{16}$	3 $\frac{1}{2}$	Blind	TCS
SO-6xxC	Uniform	6	3 $\frac{1}{2}$	3 $\frac{1}{2}$	TCS
SO-6xxCA	Uniform	6	3 $\frac{1}{2}$	Blind	TCS
SO-6xxCM	Uniform	6	4 $\frac{1}{2}$	Blind	TCS
SO-6xxVA(5)	Variable	6	3 $\frac{1}{2}$	Blind	TCS
SO-6xxV(5)	Variable	6	4 $\frac{1}{2}$	Blind	TCS
SO-6xxPV(5)	Variable	6	4 $\frac{1}{8}$	Blind	TCS
SO-6xxPLF3*	Uniform	6	3 $\frac{1}{2}$	3 $\frac{1}{2}$	Pleated Paper
SO-6xxPLBZ*	Uniform	6	3 $\frac{1}{2}$	Blind	Pleated Paper
SO-6xxVASN(5)**	Variable	6	3 $\frac{1}{2}$	Blind	Synthetic
SO-6xxVSN(5)**	Variable	6	4 $\frac{1}{2}$	Blind	Synthetic
SO-6xxPVS(5)**	Variable	6	4 $\frac{1}{8}$	Blind	Synthetic

\*The shelf life for pleated paper separators (for example, SO-xxxPLF3 and SO-6xxPLBZ) is one year.

\*\*U. S. Patent No. 8,505,742 B2 (Patent Date August 13, 2013)

### General Specifications

- TCS medium is 200 mesh stainless steel screen coated on both sides with green PTFE
- The screen is lock seam folded and fastened with an internal aluminum clip
- Pleated medium is silicone treated resin impregnated paper with a protective outer aluminum screen jacket
- Tubes are aluminum
- End caps are aluminum and/or glass filled nylon
- Gaskets are Buna-N
- pH range is 5 to 9
- Maximum operating temperature is 200°F

### SO Series cartridges

The code identification table to the left are the most commonly used. A variety of other styles are available for special applications. Contact a local area distributor for details.

SO-6xxPLF3 pleated separators come in lengths of 11,14, 16, 29, and 33 inches. SO-6xxPLBZ pleated separators come in lengths of 22, 29, 33, and 44 inches.

SO-6xxC cartridges are available in these same stackable lengths plus longer lengths. Single-unit designs, however, are recommended for installation ease and lower cost. Other styles listed in the table are not intended to be stacked.

Velcon variable size hole pattern cartridges should not be replaced with uniform hole pattern cartridges unless appropriate full-scale test data can be supplied showing equivalent performance.

For more information about EI 1581 5th Edition qualified separators, please reference data sheet 1923.

SO-6xxVASN/VSN/PVS(5) separators are intended for customers who want a separator for disposal use rather than a reusable filter, which can be cleaned a maximum of two times.



## APPENDIX H: MAINTENANCE OF PTFE COATED SCREEN SEPARATOR CARTRIDGES

DO NOT THROW PTFE COATED SCREEN SEPARATOR CARTRIDGES AWAY WHEN CHANGING COALESCERS. These separators are designed to eliminate the costly practice of replacing paper separators. It is recommended, however, that the separators be inspected, tested and cleaned at every coalescer change to assure prolonged, effective separation life. The procedure for this is described below:

1. Throughout the entire procedure, AVOID LETTING SCREEN COME IN CONTACT WITH YOUR BARE SKIN, particularly after the cartridge has been cleaned.



Hold the cartridge by the end-caps. If necessary to handle the screen during removal or installation, use a clean, dry, non-abrasive material, such as a poly-bag from one of the coalescers, between your hand and the screen.

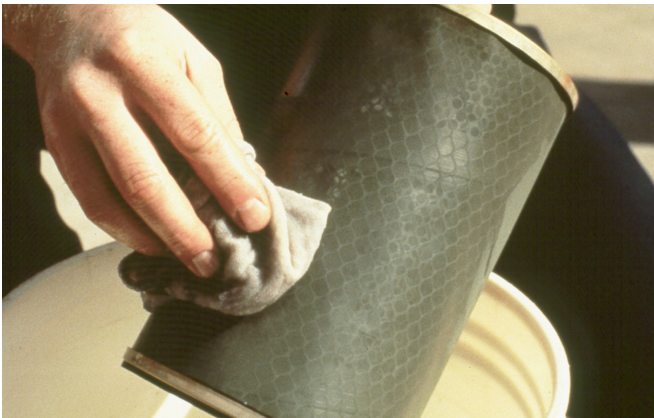

After removing the cartridge from the vessel, submerge it in clean fuel and gently scrub the entire screen surface with a soft bristle brush or a lint free cloth.

3. SURFACE INSPECTION. Holding the cartridge by the endcaps, visually inspect the entire surface of the screen for any nicks or cuts. If there are any visible flaws, they should be patched (see Step 6).



4. WATER TEST. Be sure that the separator is fuel-wetted before performing this test. Hold the cartridge by the end-cap at an angle, and gradually pour water over the entire screen surface. Do not spray the water and do not let it fall more than a distance of three inches before contacting the screen.

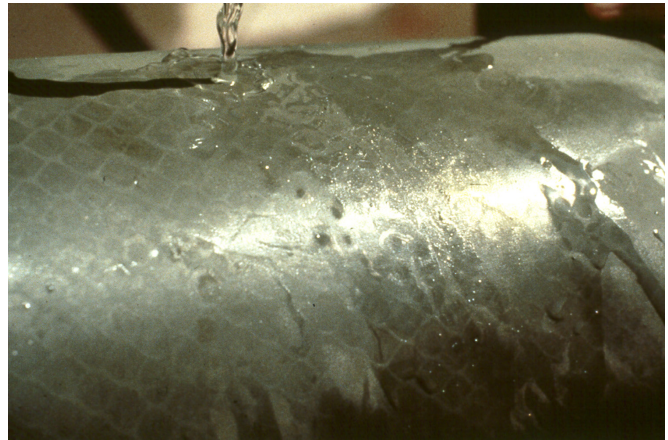

5. The water will bead and roll off the surface of properly functioning separators (as it would on a freshly-waxed car). If this is the case, the separator has passed the Water Test and can be reused. If any portion of the PTFE coated screen is wetted by the water (the water will seep into the pores of the screen; this is very obvious to the eye), the cartridge has failed the Water Test. The wetted area must be cleaned again (see Step 7), and the recleaned cartridge should pass the Water Test before it is reinstalled.

<b>NOTE</b>	The separator in the photo above has been purposely disarmed to show a water-wetted surface.
-------------	--

- 6. If the separator passes the Surface Inspection and Water Test, rinse it thoroughly in clean fuel to remove traces of water. Let the separators air dry prior to reinstalling.
- 7. If a separator fails the Surface Inspection due to visible nicks, cuts, or other flaws in the screen that can be caused by mishandling, they can be patched if they are smaller than 1/8 inch. Use two-part epoxy base putty. Thoroughly clean area with isopropyl alcohol before applying putty.

- 8. If a separator fails the Water Test due to visible wetted areas, try washing the cartridge with hot water. Use pressurized hot water from a tap or hose and thoroughly spray the wetted area. Scrubbing with a soft brush will often help on stubborn areas. Allow the cartridge to dry, then perform the Water Test again. If the cartridge continues to fail the Water Test, it must be replaced.
- 9. If gaskets should become dislodged, thoroughly clean gasket and end-cap surfaces with a solvent such as MEK or Acetone. Apply a super glue cyanoacrylate adhesive, such as Bostik #7432, to end-cap. Place gasket onto end-cap, applying pressure over entire surface of gasket. Let dry approximately 30 seconds.
- 10. REMINDER. While reinstalling the PTFE coated screen separators, be sure to avoid handling the screen with your bare hands. If you must handle the screen, use a clean, dry, non-abrasive material, such as a poly-bag. Be sure to remove all poly-bags prior to closing vessel.

**ALWAYS REPEAT THE WATER TEST TO ENSURE A GOOD PATCH.**

**BE SURE THAT THE SEPARATOR IS FUEL-WETTED BEFORE PERFORMING THIS TEST.**

<b>NOTE</b>	The above cleaning instructions are also applicable to the Velcon synthetic media separators. These can be cleaned a maximum of two times before they should be replaced.
-------------	---

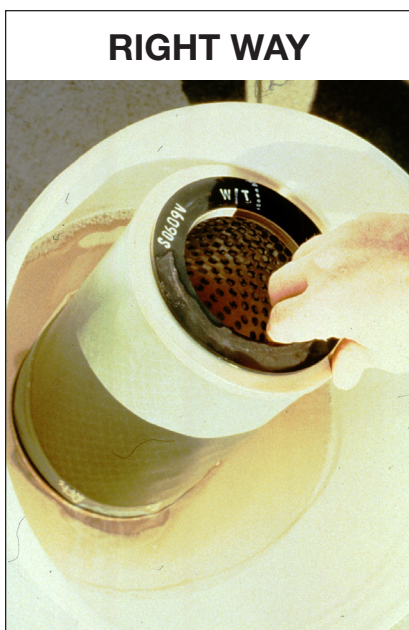

**Handle Cartridge Carefully**

**Do Not Touch the PTFE Sides!**





## APPENDIX I: COALESCER/SEPARATOR CARTRIDGES FOR AVIATION FUEL – EI 1581 5TH EDITION

### COALESCERS

The I-6xxC5 (TB), I-6xxMM, I-6xxA4, and I-6xxJF5 (TB) Series coalescers (“xx” denotes nominal cartridge length) incorporate multi-layered pleated media designed to provide superior dirt holding capacity in the field, combined with 0.4 micron efficiency. The I-6xxC5 (TB) replaces both Velcon’s I-6xx85 (TB) and I-6xx87 (TB) cartridges. These cartridges are available in either threaded base or open-end configuration. For more information on dimensions and general specifications please reference Velcon’s data sheet on coalescer cartridges (lit #VEL1732).



PTFE Coated Screen Separators



I-614C5TB  
Coalescer

### SEPARATORS

The SO-6xxV5, SO-6xxPV5, and SO-6xxVA5 are PTFE Coated Screen (TCS) cartridges. SO-6xxVSN(5), SO-6xxPVSN (5), and SO-6xxVASN (5) are synthetic separator cartridges. To achieve optimum flow distribution all of these cartridges incorporate a variable hole pattern inner tube combined with a uniform hole pattern outer tube specifically designed for installation in vertical filter/separators. Please refer to Velcon’s data sheet #1521 for overall separator dimensions and general specifications.

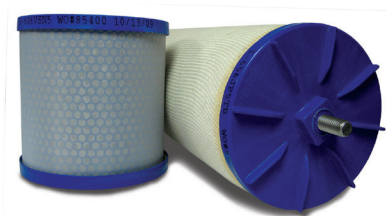

EI 1581 5th Edition Separator  
and Coalescer

### CATEGORY FUELS

Parker AFD has tested and qualified a comprehensive range of products to meet the EI 1581 6th Edition Specification.

#### • CATEGORY C

This category replaces the previous class A, B, & C of EI 1581 Third Edition. Velcon’s new coalescer cartridges that meet Category C requirements are the I-6xxC5 Series (“xx” denotes nominal cartridge length). These cartridges have been developed to provide better water removal performance in surfactant-laden fuels, and improved filtration efficiency combined with longer life. Category ‘C’ cartridges can be used at any point in the fuel distribution system – from refineries to into-plane fueling.

All of Velcon’s PCS Separator Cartridges are qualified for Category C.

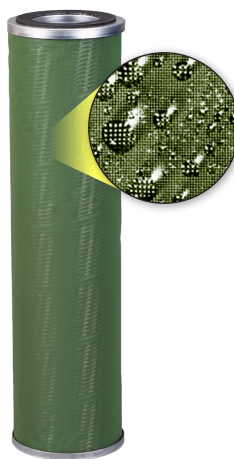

Close-up of water being  
repelled by separator



Synthetic Separators

**• CATEGORY M**

This category covers military fuels, such as JP8 (similar to Jet A but containing anti-icing and other additives). Velcon's coalescer products for this category are the I-6xxMM Series cartridges. The separators for this category are currently TCS Separators SO-6xxV5, SO-6xxVA5, and SO-6xxPV5, as well as Synthetic Separators SO-6xxVSN, SO-6xxPVSN, SO-6xxVSN5 and SO-6xxVASN.

Category M qualified cartridges also qualify for Category C.

**• CATEGORY M100**

This category is for military fuels such as JP8+100. The '+100' additive allows fuels to run at higher operating temperatures and reduces maintenance for high performance military jet engines. Velcon's coalescer cartridges for the M100 Category are the I-6xxA4 Series. The TCS Separators for M100 are currently the SO-6xxCM and SO-6xxGS (three-stage).

**ADDITIONAL INFORMATION**

The 5th Edition also allows operators to incorporate third stage filter cartridges with each category. Velcon has currently qualified the CDF®-P Series monitor (water absorbing) cartridges for Category C and the FOW-2xx Series filter cartridges for Category M100.

Another aspect of the EI 1581 5th Edition specification is the description of filter/separators as Type S (water and dirt), Type S-LW (for applications where low amounts of water are expected) and Type S-LD (for applications where low amounts of dirt are expected). Products qualified for Type S are also qualified for Types S-LD and Type S-LW.

To obtain your authorized Velcon EI 1581 5th Edition Similarity Data Report for existing vessels, please complete data sheet #1728, Velcon Similarity Certification form.

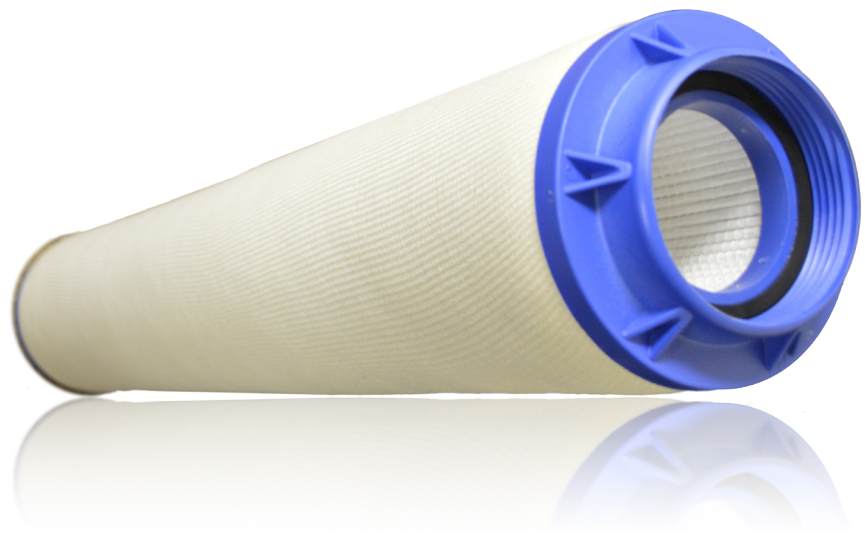

### APPENDIX J: SIMILARITY CERTIFICATION FORM

**Email:** velconcs@parker.com  
**Fax No.:** 719-531-5690  
**To: Parker Hannifin Corporation**  
**Aerospace Filtration Division**  
1210 Garden of the Gods Road  
Colorado Springs, CO 80907-3410  
**Attn: Aviation Product Manager**

**Date:** \_\_\_\_\_  
**From:** \_\_\_\_\_  
**Company:** \_\_\_\_\_  
**Address:** \_\_\_\_\_  
\_\_\_\_\_  
**Phone:** \_\_\_\_\_  
**Email:** \_\_\_\_\_

Please recommend coalescer cartridges, separators, monitor cartridges and conversion hardware, if any, for the vessels listed below to qualify them to EI 1581 6<sup>th</sup> Edition, or EI Certificate as appropriate, to satisfy requirements of ATA 103 and JIG.

**1** Vessel Model No. \_\_\_\_\_ Max Flow Rate \_\_\_\_\_ USGPM ( ) LPM ( )  
Serial No. \_\_\_\_\_ Unit No. \_\_\_\_\_ Cover Gasket No. \_\_\_\_\_  
Presently Installed: Qty \_\_\_\_\_ Model No. \_\_\_\_\_ Coalescer Cartridges  
Qty \_\_\_\_\_ Model No. \_\_\_\_\_ Separator Cartridges  
Qty \_\_\_\_\_ Model No. \_\_\_\_\_ Monitor Cartridges  
Fixed ( ) Mobile ( )  
EI-1581 6<sup>th</sup> Edition: Category C ( ) Category M ( ) Category M100 ( )  
EI-1583 Certificate ( ) EI-1590 Certificate ( )

**2** Vessel Model No. \_\_\_\_\_ Max Flow Rate \_\_\_\_\_ USGPM ( ) LPM ( )  
Serial No. \_\_\_\_\_ Unit No. \_\_\_\_\_ Cover Gasket No. \_\_\_\_\_  
Presently Installed: Qty \_\_\_\_\_ Model No. \_\_\_\_\_ Coalescer Cartridges  
Qty \_\_\_\_\_ Model No. \_\_\_\_\_ Separator Cartridges  
Qty \_\_\_\_\_ Model No. \_\_\_\_\_ Monitor Cartridges  
Fixed ( ) Mobile ( )  
EI-1581 6<sup>th</sup> Edition: Category C ( ) Category M ( ) Category M100 ( )  
EI-1583 Certificate ( ) EI-1590 Certificate ( )

**3** Vessel Model No. \_\_\_\_\_ Max Flow Rate \_\_\_\_\_ USGPM ( ) LPM ( )  
Serial No. \_\_\_\_\_ Unit No. \_\_\_\_\_ Cover Gasket No. \_\_\_\_\_  
Presently Installed: Qty \_\_\_\_\_ Model No. \_\_\_\_\_ Coalescer Cartridges  
Qty \_\_\_\_\_ Model No. \_\_\_\_\_ Separator Cartridges  
Qty \_\_\_\_\_ Model No. \_\_\_\_\_ Monitor Cartridges  
Fixed ( ) Mobile ( )  
EI-1581 6<sup>th</sup> Edition: Category C ( ) Category M ( ) Category M100 ( )  
EI-1583 Certificate ( ) EI-1590 Certificate ( )

**EXAMPLE (For EI-1581 6<sup>th</sup> Edition Conversion)**

Vessel Model No. HV-2833M150 Max Flow Rate 755 USGPM ( ) LPM ( )  
Serial No. SO54321 Unit No. Truck #127 Cover Gasket No. G-0769  
Presently Installed: Qty 7 Model No. I-633C5TB Coalescer Cartridges  
Qty 2 Model No. SO-636V Separator Cartridges  
Qty \_\_\_\_\_ Model No. \_\_\_\_\_ Monitor Cartridges  
Fixed ( ) Mobile (X)  
EI-1581 6<sup>th</sup> Edition: Category C (X) Category M ( ) Category M100 ( )  
EI-1583 Certificate ( ) EI-1590 Certificate ( )







Parker Hannifin Corporation  
**Aerospace Filtration Division**  
1210 Garden of the Gods Road  
Colorado Springs, CO 80907  
phone 719 531 5855  
[www.velcon.com](http://www.velcon.com) | [www.parker.com](http://www.parker.com)